

E-SERIES and ESC-SERIES

Evaporative Cooling

TECHNICAL MANUAL

⚠WARNING:

Improper installation, adjustment, alteration, service or maintenance can cause property damage, injury or death. Read the installation, operating, and maintenance instructions thoroughly before installing or servicing this equipment.



LIMITED WARRANTY

The Cambridge Air Solutions Limited Warranty is included with the Terms and Conditions that are sent with every Order Acknowledgement. For questions regarding the Limited Warranty, contact the Cambridge Air Solutions Customer Service Group at 1-800-473-4569 during the hours of 8:00 a.m. to 5:00 p.m. Central Time, Monday through Friday.

Copyright © 2022
Cambridge Air Solutions
All Rights Reserved

Cambridge Air Solutions
760 Long Road Crossing Dr.
Chesterfield, MO. 63005
Phone: (636) 532-2233, (800) 899-1989
Fax: (636) 530-6133
www.cambridgeair.com

E-SERIES and ESC-SERIES

Evaporative Cooling

TECHNICAL MANUAL

CONTENTS

SAFETY CONSIDERATIONS	4
OVERVIEW OF MANUAL.....	5
RECEIVING, OFFLOADING, AND RIGGING INSTRUCTIONS.....	5
Receiving Checklist.....	5
Resolving Shipping Damage.....	6
Forklifting Considerations	6
Preparing the Unit Site	6
Offloading and Rigging Instructions.....	6
General Lifting Considerations.....	7
Unit Placement and Assembly.....	7
SECTION TO SECTION ASSEMBLY	7
Assembly Hardware	8
INSTALLATION – MECHANICAL	8
INTERNAL ASSEMBLY	8
EXTERNAL CONNECTIONS.....	8
Duct Connections.....	8
Plumbing/Fill and Drain Valves.....	8
FILL and DRAIN VALVE SCHEMATIC	9
FILL VALVE SCHEMATIC	10
FILL and DRAIN VALVE SCHEMATIC	11
ELECTRIC PANEL/WIRING	12
MEDIA COOLING PADS OPERATING INSTALLATION.....	13
Coil Piping Recommendations.....	14
Condensate Drain Connections.....	14
Gas Piping	14
Electrical Connections	15
START-UP	15
START-UP CHECKLIST.....	16
BELT TENSION	17
MAINTENANCE.....	18
TROUBLESHOOTING.....	20
SERVICES AVAILABLE.....	20
ORDER NOTES	20
CAMBRIDGE AIR SOLUTIONS PARTS LIST (COMMON PARTS)	21

SAFETY CONSIDERATIONS

Throughout this manual are Warnings, Cautions and Notes to alert the installing contractors, service and maintenance personnel of potential hazards that could result in personal injury, death or serious damage to property or equipment.

Your personal safety and the proper operation of this machinery depend on the careful observance of all Warnings, Cautions and Notes:

⚠️WARNING:

Indicates a potentially hazardous situation which, if not avoided, could result in death or serious injury.

⚠️CAUTION:

Indicates a potentially hazardous situation which, if not avoided, could result in minor or moderate injury, or to alert against unsafe practices.

NOTE: Indicates a situation that could result in equipment or property damage, or provides important information on installation considerations.

⚠️WARNING:

Proper Field Wiring and Grounding Required!
All field wiring MUST be performed by qualified personnel. Ensure all field wiring and grounding is accomplished in full accordance with National Electrical Code (NEC) and local/state electrical codes. Failure to do so may pose FIRE or ELECTROCUTION hazards resulting in death or serious injury.

⚠️WARNING:

Personal Protective Equipment (PPE) Required!
Installing/servicing this unit could result in exposure to electrical, mechanical and chemical hazards.

- Before installing/servicing this unit, technicians MUST wear all recommended Personal Protective Equipment (PPE) for the specific work being undertaken.

ALWAYS refer to appropriate Safety Data Sheets (SDS) sheets and OSHA guidelines for proper PPE.

- When working with or around hazardous chemicals, ALWAYS review appropriate SDS and OSHA guidelines to ensure compliance with safety standards for personal exposure levels, proper respiratory protection and handling recommendations.
- If there is a risk of arc flash, technicians MUST put on all PPE in accordance with the National Electrical Code (NEC) for arc flash protection, PRIOR to servicing the unit.
- Failure to follow recommendations could result in death or serious injury.

OVERVIEW OF MANUAL

Cambridge Air Solutions E-Series and ESC-Series units are air handlers that use evaporative cooling to meet specific usage and dimensional requirements. These models come with various options including service access location, utility connections, airflow arrangement and accessories. Use this manual to install, start-up, operate, and maintain the Cambridge Air Solutions evaporative units. A careful review of this manual will help minimize installation, startup, and maintenance difficulties.

NOTE: For more detailed information on individual evaporative cooling, heating, and control components refer to individual manufacturer's technical manuals.

Unit Description

The E-Series and ESC-Series units are semi-custom designed for a variety of applications. The basic unit consists of an evaporative cooling section, fan, filters, and dampers. Heating and cooling coils are available on the ESC-Series units only. The unit ships as a complete assembly whenever possible and in sections based upon customer request or shipping requirements. Units shipped split will require field connection by the installing contractor.

RECEIVING, OFFLOADING, AND RIGGING INSTRUCTIONS

Upon receipt of the air handler(s), a thorough inspection should be performed to note any shipping damage that may have occurred and that the shipment is complete. Factory shipping protection should be removed immediately to allow complete access for the inspection. The shipping protection provided by the factory is for transit protection only and should not be used as a jobsite storage cover.

Receiving Checklist

- Check all access doors to confirm that the latches and hinges are not damaged.
- Inspect the interior of each section for any internal damage.

NOTE: Concealed damage must be reported within 5 days of receipt.

- Inspect the coils for damage to the fin surface and/or coil connections.
- If the unit was ordered with factory-mounted controls, locate all sensors.

Operating Environment

The unit is designed for outdoor applications. When considering the placement of the air handler, it is important to consider the operating environment. The acceptable ambient temperature range for unit operation is -10 to 115° F.

⚠ CAUTION:

Do not subject the unit to temperatures over 140°F/60°C.

NOTE: Careful consideration is also required if the air handler(s) will be installed within a coastal temperate zone. Additional protective coatings may be necessary to prevent corrosion.

NOTE: Items that are shipped loose will be located inside the unit and identified.

- Check all control devices attached to the unit exterior and confirm that they are not damaged.
- Manually rotate the fan wheel to ensure free movement of the shaft, bearings, and drive.
- Inspect the fan housing for any foreign objects.
- If the unit is shipped in sections, locate the assembly hardware, which should be packaged and shipped inside a section of the unit.
- Inspect and test all piping for possible shipping damage. Nipples may be installed on coils at the factory but should always be tightened and tested before any connections are made. Rough handling during shipping, in addition to other factors can cause pipe connections to become loose.

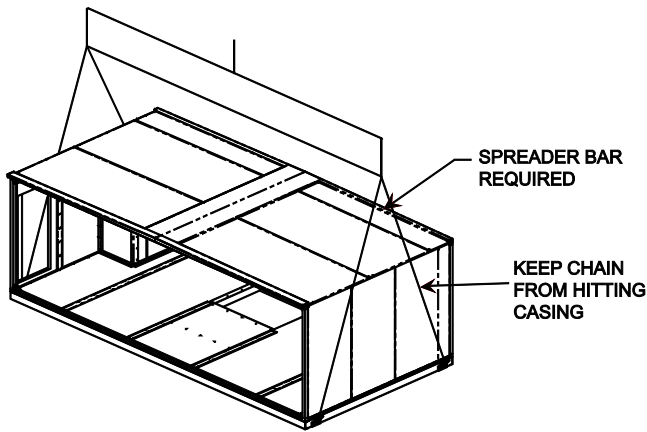

Resolving Shipping Damage

NOTE: Cambridge Air Solutions is not responsible for shipping damage.

Cambridge Air Solutions air handlers ship freight-on-board (FOB).

Ownership of the units transfers to the customer the moment the delivery truck leaves the Cambridge Air Solutions factory. If damage has occurred to the unit during shipment, follow these instructions:

1. Make specific notation, describing the damage, on the freight bill. Take photos of the damaged material if possible.
2. Report all claims of shipping damage to the delivering carrier immediately and coordinate carrier inspection if necessary.
3. Contact Cambridge Air Solutions immediately for replacement of damaged parts or components.

NOTE: Do not attempt to repair the unit without consulting the delivering carrier and Cambridge Air Solutions.

Forklifting Considerations

WARNING: Refer to unit submittals for weight and forklift limitations before attempting to use a forklift for offloading.

A forklift may be used to lift a single section provided the forks extend under both ends of the base frame. The forks should not contact the bottom of the air handler. Units should only be lifted from the proper end identified by the lifting label on the unit. A lifting crane or other means should be used for larger units where forks cannot extend under both base rails.

Preparing the Unit Site

Ensure the installation site can support the total operating weight of the unit and curb or rails. Refer to the unit submittals for actual weights. Preparation of roof curb or mounting pad should be completed before hoisting/rigging unit to roof or pad. Refer to submittals for specific Cambridge Air Solutions minimum requirements.

General Notes:

- Allow room for all piping, ductwork, and electrical connections, and fan and coil removal.
- Ensure there is adequate height for condensate drain requirements.
- Confirm the roof curb or foundation of the mounting platform is level and large enough to accommodate the unit. Refer to the unit submittals for specific dimensions.
- Provide adequate lighting for maintenance personnel to perform maintenance duties.
- Provide permanent power outlets in close proximity to the unit for installation and maintenance.

Rooftop curb-mounted units must be sealed tightly to the curb. Use proper sealants and roof-to-curb sealing techniques to prevent water and air leakage prior to air handler installation.

Offloading and Rigging Instructions

Field rigging procedures will vary. Lifting brackets are built into the unit. Additional lifting brackets/clips may be provided with the unit when required. Use a spreader bar and proper rigging and lifting procedures to avoid equipment damage and personal injury.

General Lifting Considerations

Before preparing the unit for lifting, estimate the approximate center of gravity for lifting safety. Because of placement of internal components, the unit weight may be unevenly distributed, with more weight in the coil and fan areas. Refer to the unit submittals for actual section weights. Test the unit for proper balance before lifting.

Preparation of the roof curbs or pier mounts and roof openings must be completed before lifting to the roof.

- Always rig sections as they ship from the factory.
- Never bolt sections together before rigging.
- Use all lifting lugs provided. The air handler is not designed to be lifted or rigged from the top of the unit.
- Never stack the inlet hood on the unit as it is being lifted.
- Do not attach the intake hood (if shipped loose) to the unit prior to lifting the unit. Doing so may damage the equipment. Attach the hoods to the unit only after all sections are in place.
- All shipping supports and crating on the face of the sections must be removed to permit proper fit-up and sealing of the surfaces. Dispose of properly.

Unit Placement and Assembly

After assembling and hoisting the unit, mount it on its roof curb or rail mount. Make sure that the gasket around the base channel provides an airtight and watertight seal. The unit should be supported by its base channel, around the entire perimeter of the unit. Check that the unit is level to ensure proper operation. For downblast units, allow space for duct connections under the unit.

Adequate clearance must be provided around unit for service access and free air passage. Allow sufficient room to pull coils and fans if necessary. If unit is enclosed by walls or other obstructions on all four sides, allow a minimum of 72" clearance on all four sides.

NOTE: Cambridge Air Solutions air handling units typically ship complete. Based on unit size and customer requirements, units may ship in sections and need to be field assembled.

If a unit arrives in sections, then each section must be individually hoisted, set on the housekeeping pad, roof curb, or rails and then assembled. Refer to the unit submittals and unit tagging for correct placement of all sections. If there are any discrepancies between the submittals and the unit tagging, contact your local Cambridge Air Solutions representative before proceeding. Following the order of the sections on the unit submittals and tagging, individually place each unassembled section in the appropriate installation location.

Section to Section Assembly

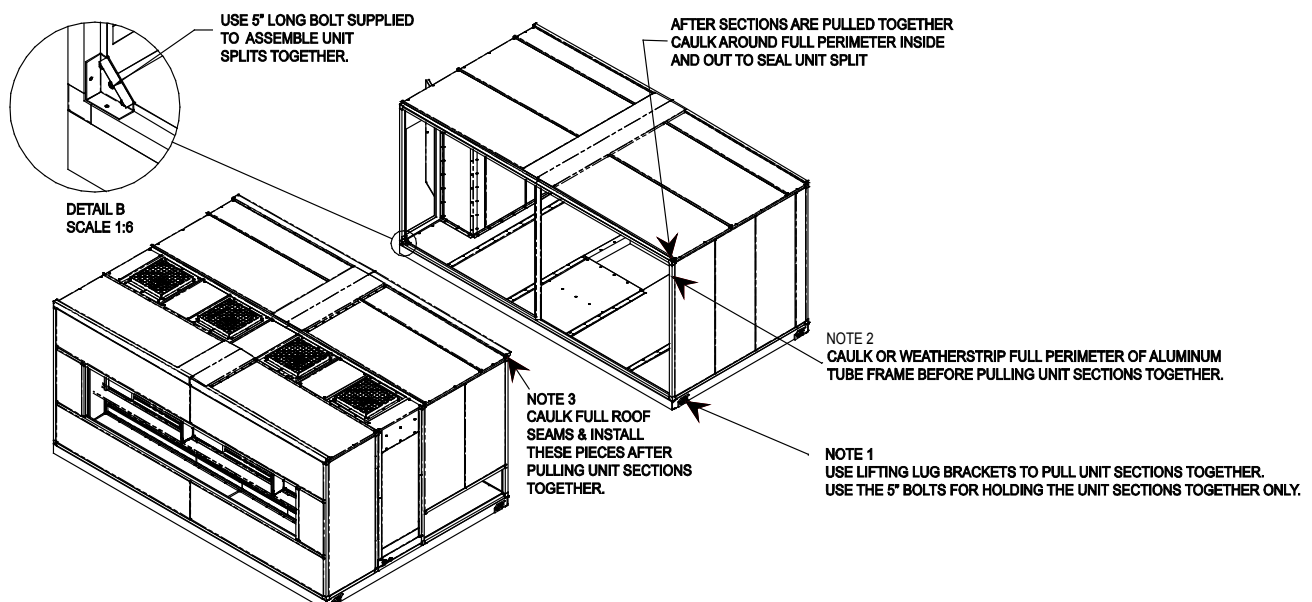

Assembly Hardware

Cambridge Air Solutions air handlers ship with all necessary assembly hardware and gasket material located inside the unit. If there is not enough space inside a section, then a crate or pallet will be loaded onto the bed of the truck.

Check all sections thoroughly before contacting your Cambridge Air Solutions Sales Representative to report missing items.

NOTE: Do not proceed with unit assembly until verification that all materials are present.

Sections are joined with a gasket applied to one of the mating surfaces and hardware to bolt the sections together. 1" wide closed cell foam gasket with adhesive backing is used for section-to-section joints.

INSTALLATION — MECHANICAL

NOTE: All work to conform to local, state, and national codes and ordinances and per approved submittals.

INTERNAL ASSEMBLY

Component Installation Requirements

NOTE: The components in the air handler may have installation requirements that could affect the unit's performance.

Typical components include, but are not limited to, Inlet Hoods or Louvers, Dampers, Filters, Evaporative Cooling Sections, Fans and Isolation, Control and Electric Panels, Gas Heaters, Coils and Valves.

Additional information to install and/or adjust components can be referenced from the manufacturer's technical manuals and are attached for your reference.

EXTERNAL CONNECTIONS

NOTE: Air handlers often include factory-provided casing penetration (entry points) for field-provided piping and wiring. Consider overall unit serviceability and accessibility, mentioned previously, before mounting and installing any permanent connections to the cabinet.

Duct Connections

All duct connections to the air handlers should be installed in accordance with the standards of the National Fire Protection Association (NFPA) and all other local, state, and national codes and ordinances, including:

- NFPA 90A Standard for the Installation of Air-Conditioning and Ventilating Systems for installing air conditioning and ventilating systems other than residence type.
- NFPA 90B Standard for the Installation of Warm Air Heating & Air-Conditioning Systems.
- See unit submittal documentation & specifications for any additional duct mounting information.

Fan Discharge Connections

To ensure the highest fan efficiency, duct turns and transitions must be made carefully, minimizing air friction losses and turbulence. Proper ductwork installation, as outlined by such organizations as Sheet Metal and Air Conditioning Contractors National Association, Inc. (SMACNA), should be followed closely.

PLUMBING / FILL AND DRAIN VALVES:

1. All installation should be performed in accordance to local and state codes and with proper permits.
2. The make-up water connection is ½" FPT.
3. Install a 3-way fill valve under the roof (in a conditioned space) to keep the pipe from freezing (see attached schematic).
4. The 2-way drain valve can be installed outdoors or indoors under the roof line in a frost-free environment. See schematic below. If the 2-way drain valve is installed outdoors (above the roof level), valve cover(s) are required.

Auto Drain with Freeze Protection (Optional)

Install a two-way drain valve on the sump's drain connection. Install a three-way fill valve under the roof-line with port "AB" piped to the make-up water

connection from the sump. Port "A" is piped to the city water supply and port "B" is piped to an approved roof drain. (See attached drawing.)

During normal operation of the unit the drain valve will be shut and the fill valve is open from port "A" to port "AB" letting city water enter the sump. Water level is adjusted and controlled by a float assembly to a level ½" inch below the overflow. On a freeze signal or a signal from the 24-hour time clock, the drain valve will open allowing the sump to drain. Simultaneously, the fill valve will shut off the city water, closing port "A" to port

"AB" but will open port "AB" to port "B," thus allowing the remaining water in the exposed pipe from the valve to the sump to drain to keep the pipe from freezing. A low-water cut off switch will protect the pump(s) from running dry.

During installation, relocate the freeze stat bulb (located inside the electric control panel) to the outside of the enclosure to ensure correct temperature readings.

FILL AND DRAIN VALVE SCHEMATIC

DRAIN, OVERFLOW AND MAKE-UP WATER PIPING FOR AUTODRAIN WITH FREEZE PROTECTION

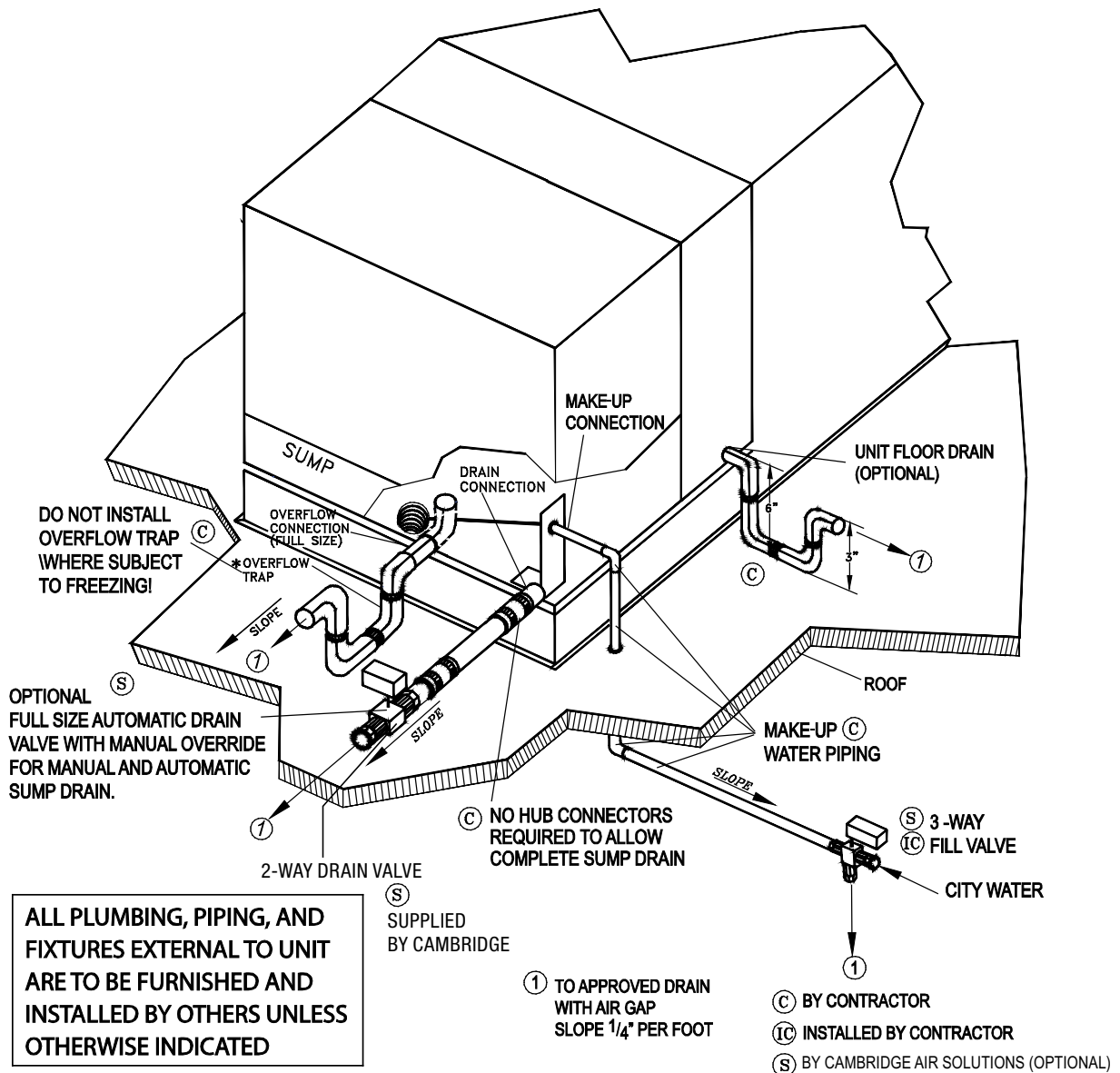

FILL VALVE SCHEMATIC:

NOTE: ALL PLUMBING, PIPING, AND FIXTURES EXTERNAL TO UNIT ARE TO BE FURNISHED AND INSTALLED BY OTHERS UNLESS OTHERWISE INDICATED.

3-WAY VALVE FILLING SUMP

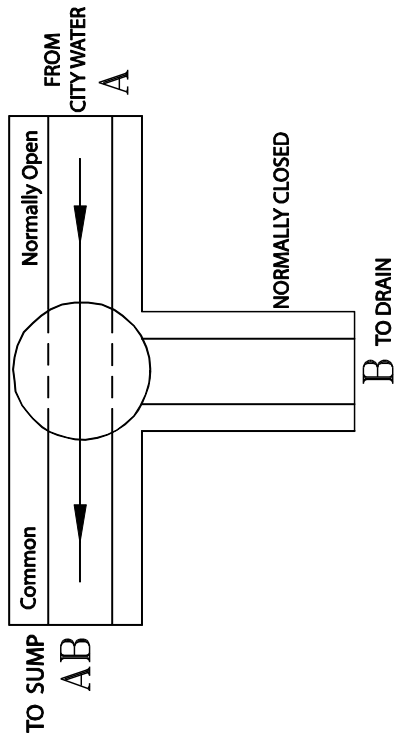

3-WAY VALVE SHUTTING OFF CITY WATER & DRAINING EXPOSED PIPE

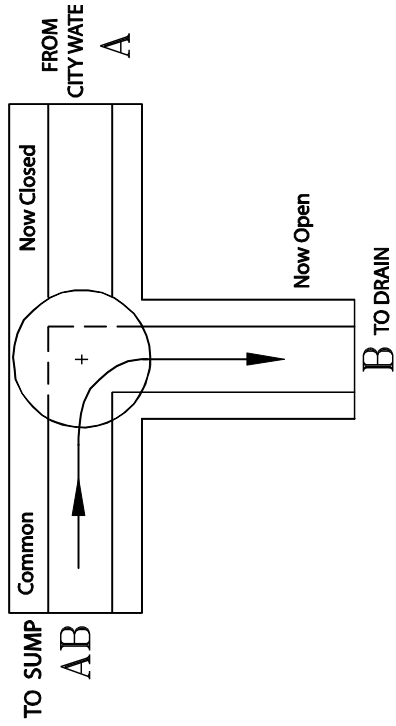

SUGGESTED MAKE UP WATER PIPING

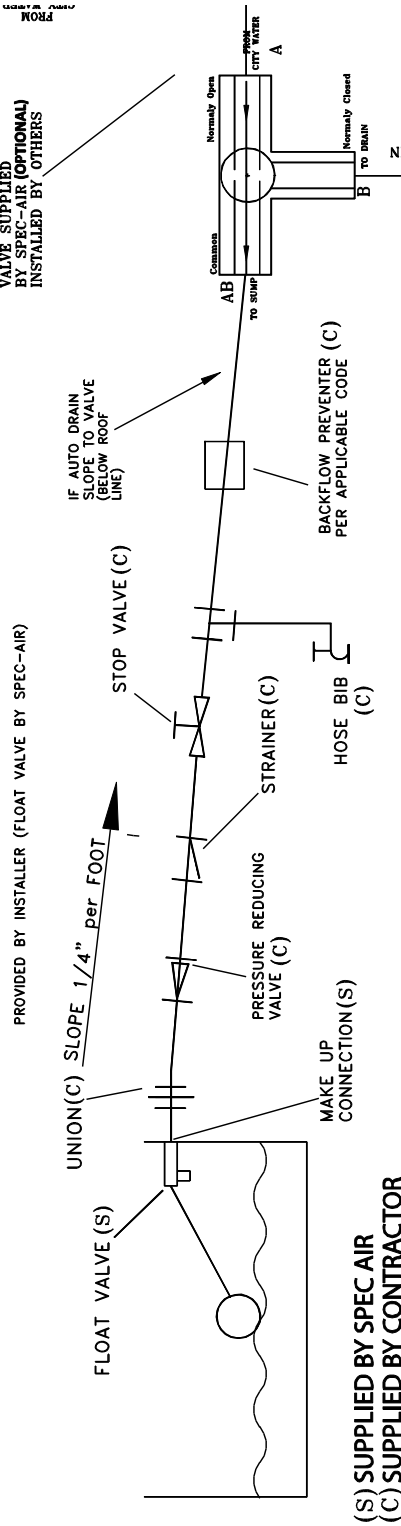

NOTE: IMPORTANT TO REDUCE POSSIBLE BUILDING FLOODING !

SET PRESSURE REDUCING VALVE TO APPROX. 5 PSI PRESSURE OVERFLOW MUST BE CAPABLE OF HANDLING MAKE-UP WATER FLOW RATE.
 TO SET: BLOCK FLOAT VALVE OPEN AND LOWER PRESSURE UNTIL OVERFLOW WILL HANDLE FULL MAKE-UP WATER FLOW RATE.

(S) SUPPLIED BY SPEC AIR
 (C) SUPPLIED BY CONTRACTOR

FILL AND DRAIN VALVE SCHEMATIC

Drain, Overflow and Make-Up Water Piping for Autodrain with Freeze Protection

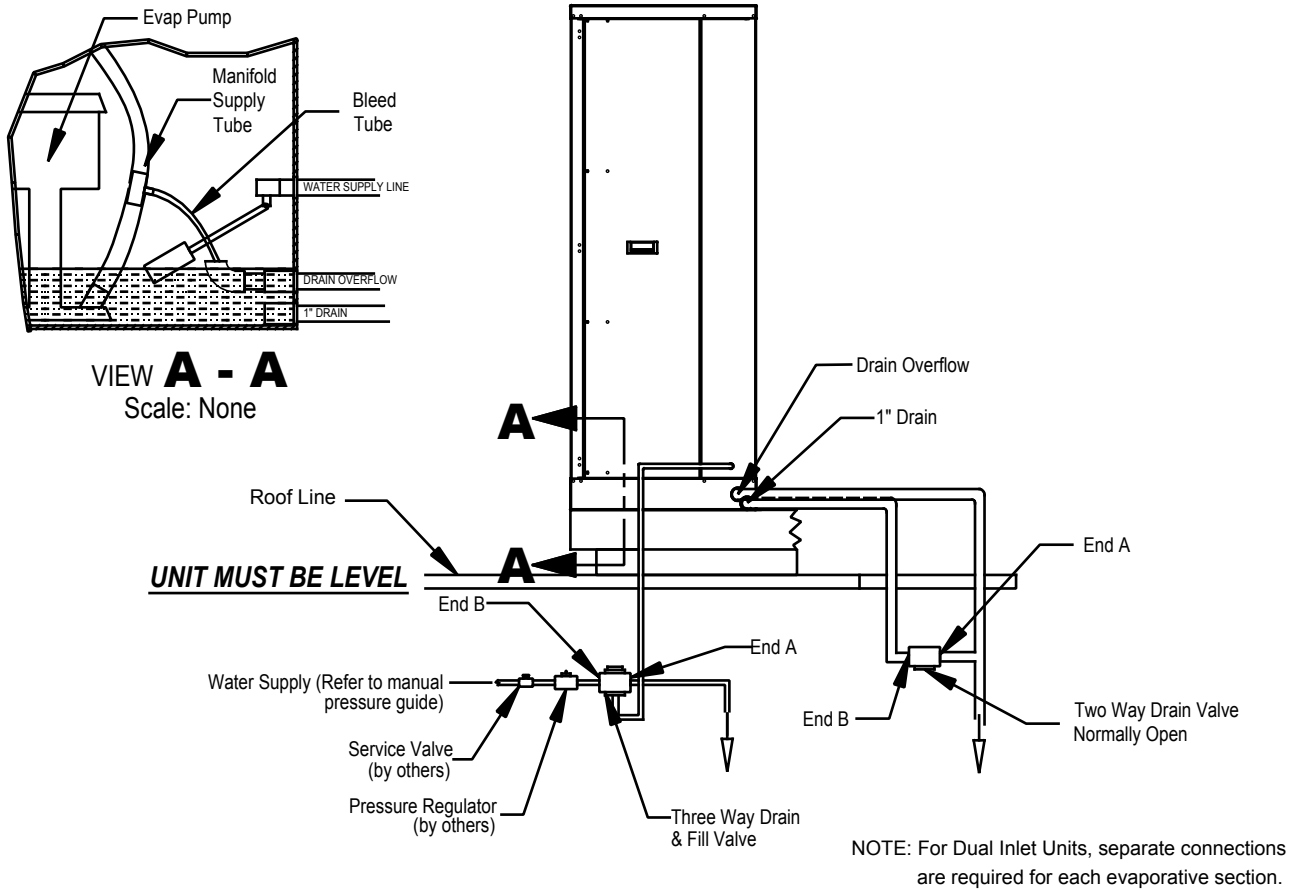

FILL & DRAIN KIT WIRING SCHEMATIC

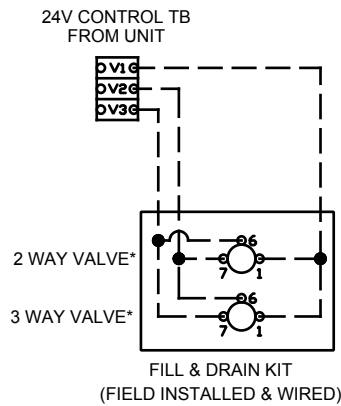

NOTE: *Wiring may change if pumps provided by others.
**All wiring must comply with local and national electrical codes.

ELECTRIC PANEL / WIRING:

The pump and low level switches are wired to a J-Box in the direct evaporative module.

Wiring to the control panel is pre-wired and coiled up in the Electrical Control Enclosure for termination in the field.

Factory-supplied power and control wiring are to be field-connected to the terminal strip located in the Jbox-mounted on the direct evaporative module.

NOTE: Power is supplied and installed by others.

- All installations should be performed in accordance to local and state codes and with proper permits.
- Wire the unit according to approved submittals and the wiring diagram.

MEDIA COOLING PADS OPERATING INSTALLATION:



Munters

Engineering Bulletin EB-OI-0906
**MEDIA ORIENTATION
 INSTRUCTIONS**

IMPORTANT

Installation

In order to get the best performance from your Munters cooling pads, they must be installed properly. If you have purchased a pad with two equal angles, they can be installed in either direction. Depending on the application, pads are manufactured with special angle combinations. Those having combinations of 15° x 45° are made to direct more water toward the air entering side of the pads. If installed backwards, the pads may not work properly.

Munters pads must always be installed with the steeper flute angle sloping down toward the air entering side. The reasoning is simple, the steeper angle puts more water on the entering side of the pad where the air is hot, dry, and dusty and extra water it is needed most. The unequal angles also counteract the tendency of the air to push the water toward the air leaving side of the pad.

CELdek "New Pad" Odor

CELdek is made from materials similar to those used in paints, carpets, paneling and wallpaper. CELdek pads must be flushed with water to remove the new construction odors. If you find the smell of the new paper to be objectionable, you should run water over the pad for 2-5 hours without the fan running. Change the water often, using bleed off or dump cycles. If the odor continues after one or two days, call Munters customer service. Please have full details of when and from whom the pad was purchased.

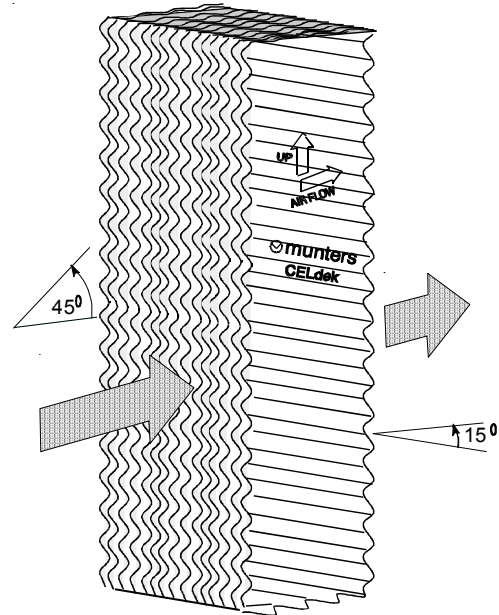

Caution

Do not expose CELdek® evaporative cooling pads to sparks, open flame, welding spatter, temperatures in excess of 350° F, or other sources which may ignite the paper. GLASdek® will not readily ignite, unless exposed to a direct flame or extremely high temperatures for an extended period of time.

Test Results for ASTM-E84 Standard Method of Test for Surface Burning Characteristics of Building Materials

PRODUCT	Flame Spread Index	Smoke Density
CELdek	450	420
GLASdek	0	20
Mi-T-Dark®, DRIFdek®, & COOLdek®	15	745

The data and suggestions contained herein are based on information Munters believes to be reliable. They are offered in good faith but without guarantee, as conditions and methods of use are beyond our control. We recommend that the prospective user determine the suitability of our media and suggestions before adopting them on a commercial scale.

For more information Contact Munters Corporation, HumiCool Division 239-936-1555

©Copyright Munters Corporation 2002 Printed in USA

Coil Piping Recommendations (ESC-Series only)

1. Proper installation, piping and trapping is necessary to insure satisfactory coil operation and to prevent operational damage.
2. Support all piping independently of the coils.
3. Provide swing joints or flexible fittings in all connections that are adjacent to heating coils in order to absorb thermal expansion and contraction strains.
4. Check that the coils are installed correctly, with airflow in the same direction as indicated on the nameplate or coil casing.
5. For best results, Cambridge Air Solutions recommends that a short pipe nipple be used on coil headers prior to making up any welded flange or welded elbow type connections. This allows the use of a back-up pipe wrench which prevents over-tightening when it is necessary to rotate the welded flange or elbow until the bolt holes line up with the mating flange on the pre-fabricated piping.

NOTE: Use a “Back-Up Wrench” when attaching piping to coils with copper headers. Do not use brass fittings or brass pipe connectors. Brass distorts easily and causes connection leaks.

6. When attaching the piping to the coil header make the connection only tight enough to prevent leaks. Maximum recommended torque is 200 foot-pounds. Use pipe sealer on all threads.
7. Connect supply and return coil piping. Verify the coil's water lines are correctly installed for counter flow operation.
8. After completing the piping connections, seal around pipe from inner panel to outer panel.
9. Provisions must be made to drain coils that are not in use when subjected to freezing temperatures.

⚠CAUTION:

Failure to properly drain and vent coils when not in use during freezing temperatures may result in coil freeze-up damage. In all steam coil installations, the condensate return connections must be at the low point of the coil.

10. Install air vents for piping per plans, specifications and submittals and per local, state, and national codes and ordinances.
11. Check for coil fin damage and straighten if necessary.

⚠CAUTION:

Do not throttle or modulate the water flow for coils that are exposed to freezing air. Coil damage may result from freeze-up.

NOTE: Cambridge Air Solutions recommends the following if not already included:

12. Install a strainer ahead of the control valve when used.
13. Install a drain line with a shutoff valve near the coil.

Condensate Drain Connections (ESC-Series only)

A condensate drain connection is provided on the door side of the fan/coil section drain pan. Check the openings for obstruction to flow. Install drain and trap per local, state, national codes, and ordinances and approved submittals.

Gas Piping (ESC-Series only)

NOTE: All unit installations must be in accordance with NFPA 54/ANSI Z223.1: National Fuel Gas Code in the United States and CSA B149.1, Natural gas and propane installation code in Canada, and all other applicable local, state, and national codes and ordinances.

Refer to gas heater manufacturer's technical manual for specific requirements.

All internal gas piping is factory installed and pressure/leak tested before shipment. Once the unit is set into place, the gas supply line must be field connected inside the gas heat control compartment.

Electrical Connections

NOTE: All field installed wiring must comply with NEC and applicable codes. Properly ground the unit. The unit, when installed must be electrically grounded in accordance with the National Electrical Code, ANSI/NFPA No. 70E.

Refer to the Cambridge Air Solutions wiring diagrams furnished with the unit, regarding factory wired and field installed wiring requirements. Actual wiring diagrams will differ according to the options used. The outdoor conduits leading into the unit should be installed to prevent rain from wetting any high voltage wire.

Install all power wiring and controls per drawings, specifications, and applicable codes.

- Verify that power supply electrical characteristics comply with unit nameplate specifications.
- Inspect all control panel components: tighten any loose connections.
- Connect properly sized and fused power supply wiring to a field supplied/installed disconnect and unit power terminal block or to an optional unit mounted disconnect switch.
- Complete field wiring for the controls, as applicable.

START-UP

Pre-Startup Checklist

Once the air handler has been assembled, installed, and piped attention must be directed to individual components for proper operation. Before operating the unit, complete the Pre-Startup checklist. Sign and send copy to Cambridge Air Solutions.

NOTE: Follow all manufacturer's guides for Pre-Start Up. The following is a guide only.

- Remove any debris from the unit interior.
- Remove all foreign material from the drain pan.
- Check drain pan opening and condensate line for obstructions.
- Ensure the unit has been installed level.
- Ensure damper operator motor and connecting linkage have been installed.
- Verify damper operation and linkage alignment.
- Check that air filters are in place and positioned properly.
- Close and secure all unit access doors.
- If a differential pressure switch is provided on filter rack, adjust per system requirements.
- Inspect electrical connections to the unit and unit controllers.
 - Connections should be clean and secure.
 - Compare the actual wiring with the unit diagrams.
 - Reference the appropriate controller manual for more details about starting units with factory-mounted controls.
- Check all items in Cambridge Air Solutions direct and indirect evaporative cooling module's Start-Up Checklist.
- Ensure supply and return air ducts have been connected properly.
- Ensure all piping, connections, vents and drains have been connected properly.
- Ensure all gas piping, connections, drains and flue vent piping have been connected properly.
- Check piping and valves for leaks. Open or close the valves to check for proper operation. Drain lines should be open.
- Leave this manual with the unit.

START-UP CHECKLIST

Once the air handler has been assembled, installed, and piped, attention must be directed to individual components for proper operation. Before operating the unit, complete the Pre Start-up checklist. Sign and send copy to Cambridge.

NOTE: Follow all Manufacturers' Guides for Pre Start-Up. The following is a guide only.

1. Remove any debris from the unit interior.
 - a. Remove all foreign material from the drain pan and check drain pan opening and condensate line for obstructions.
 - b. Ensure the unit has been installed level.
 - c. Ensure the damper operator motor and connecting linkage have been installed.
 - d. Verify the damper operation and linkage alignment.
 - e. Check that the air filters are in place and positioned properly.
 - f. Close and secure all unit access doors
2. If differential pressure switch is provided on filter rack, adjust per system requirements.
3. Inspect electrical connections to the unit and unit controllers.
 - a. Connections should be clean and secure.
 - b. Compare the actual wiring with the unit diagrams.
 - c. Reference the appropriate controller manual for more details about starting units with factory mounted controls.
4. Ensure all piping, connections, vents and drains have been connected properly
5. Ensure supply and return air ducts have been connected properly.
6. Check piping and valves for leaks.
7. Fill sump tank with water and adjust float to ½" below overflow drain.
8. Check that the fill and drain valve is installed and wired to the 24-hour timer and freeze stat. Set the 24-hour fill and drain timer to local time. The drain and refill feature is factory set to turn off the sump for 1 hour between 4 am to 5 a.m., and is manually adjustable to User's requirements.

⚠WARNING:

Whenever power is interrupted, the 24-hour clock must be reset to local time.

9. Turn power to unit on and check for any electrical shorts.
 - a. Measure and record the motor voltage and amperage on all phases to ensure proper operation. The readings should fall within the range given on the motor nameplate.
 - b. Check fan rotation and correct if necessary.
 - c. Check all interlocks to be sure that connected components work per plans and specifications.
10. Check that line and sump pump voltages and amperages as per the nameplate.
11. Confirm the time delay has been set to 1 minute on the sump pump(s).
12. Verify the low water level float switch located in sump is working properly and will turn the pump(s) on.
13. Start-up the fan per manufacturer's instructions. After both the fan and sump are running and operating properly, check that water is not being carried over into the airstream from the media pads or sump.
14. Cycle damper actuators to ensure they open and close freely.

If there is water carryover from the media pads perform the following procedure:

15. Check for proper positioning of media pads on the sides of the pads are arrows marking the direction of air flow. If media pads are correctly positioned then check for air bypassing between the media pads and their frames. If air is bypassing, then place a strip of foam gasketing between the media pads and side channel to compress the media pads and fill the gap.
16. After twenty (20) minutes observe media for complete wetting and check that there are no dry streaks. Open balancing valve to increase water flow and close valve as necessary to reduce water flow to media pads. (Initial factory-set position of valve is ½ open).

17. After running the unit for (1) week adjust factory pre-set bleed valve(s). This process allows the pump to discharge the concentration of solids in the water. The bleed valve is located on the discharge portion of the pump and is connected to a 3/8" drain tube. The drain tube should always be positioned inside the overflow drain. Use the following procedure to set bleed valve:

- i. Completely turn the bleed valve(s) open. This allows the pump to discharge the concentration of solids in the water.
- ii. Close the bleed valve(s) and count the number of turns required.
- iii. Set bleed valve(s) to ½ open position.
- iv. Check that bleed lines(s) are connected to overflow drain.
- v. Increase water flow rate if there are scale deposits on the media pads. Check for water carryover afterwards and adjust if necessary.
- vi. If there are dry streaks in the media then remove distribution header and any debris blocking the distribution holes.

- a. Open or close the valves to check for proper operation.
- b. Drain lines should be open.

18. Leave this manual with the unit.

Conductivity/Total Dissolved Solids (TDS) Controller

Start up the controller per manufacturer's Installation & Operation Manual (IOM), based on the recommendations of your local water quality expert to ensure proper water quality in the evaporative cooling units.

BELT TENSION:

Proper belt tension is important for long belt life. Too much tension will place excessive loads on the belts and bearing, causing premature failure. Not enough tension will cause belts to slip generating dust and heat while reducing the belt life. Use a belt tension tool to check the belt's tension. Ideal belt tension is the lowest tension at which the belts will not slip under peak load conditions. Before starting the fan, recheck the alignment and realign the sheaves if necessary. New belts may stretch after installation, so recheck belt tension frequently during the first 24-48 hours of operation. Make drive inspections on a periodic basis. Never apply belt dressing.

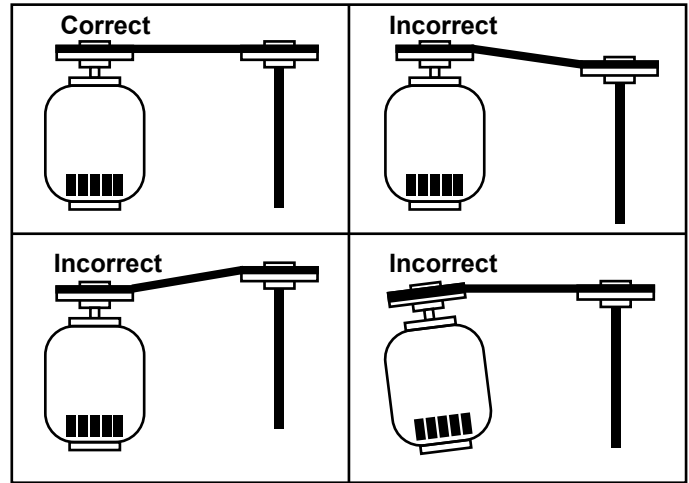

NORMAL OPERATIONS:

Sequence of Operation:

1. Upon external signal the sump pump will energize and water will flow to the distribution header and over the media pads.

NOTE: For longer media pad life do not cycle the water flow over the media pads. The pump should run continuously (Variable air volume or cycling the fan are acceptable methods of temperature control).

If the pump has to be cycled, a wash down cycle component can be utilized to prevent the plating of solids on the media.

2. At the factory pre-set or customer-set time, the fill valve will close and the drain valve will open for one hour emptying the sump.

NOTE: This procedure is necessary to prevent algae and scale formation on the media pads.

MAINTENANCE

The following are general maintenance procedures and guidelines and should be used for reference purposes only. Refer to manufacturer's technical manuals for specific procedures and frequency.

Maintenance Checklist

Frequency of Maintenance

After 48 hours of operation

- For belt-drive fans, the belts have acquired their permanent set. Readjust but do not overtighten.

Every week

- Observe unit weekly for any change in running condition and unusual noise.

Every month

- Clean or replace air filters if clogged or dirty; coat permanent filters with oil after cleaning; filters per manufacturer's recommendations.
- Belt-drive fans: Re-lubricate fan bearings if necessary. Check and adjust fan belt tension.

Every three to six months

- Belt-drive fans - check fan bearing grease line connections. Lines should be tight to the bearings.
- Check motor bracket torque.
- Belt drive fans: check bearing bolt torque and bearing setscrew torque.
- Belt-drive fans: align fan and motor sheaves.
- Inspect and clean drain pans.
- Tighten electrical connections.
- Inspect coils for dirt build-up.

Every year

- Inspect the unit casing for corrosion. If damage is found, clean and repaint.
- Clean fan wheels and shaft.
- Inspect and clean drain pans.
- Check damper linkages, set screws, and blade adjustment. Clean, but do not lubricate, the nylon damper rod bushings.
- Check door handles for proper fit and operation, adjust if necessary.
- Check condition of gasket and insulation around unit, door and dampers.
- Inspect electrical components and insulation.
- Inspect wiring for damage.
- Rotate the fan wheel and check for obstructions. The wheel should not rub. Re-center the wheel, if necessary.
- Lubricate motor bearings in accordance with motor manufacturer's recommendations.
- Examine flex connections for cracks or leaks. Repair or replace damaged material.

Cambridge Air Solutions Direct and Indirect Evaporative Cooling Modules Maintenance Procedure:

Spring Start-Up

1. Clean any scale or debris in pump and sump area.
2. Remove distribution header and clean out distribution holes that supply water flow to media pads.
3. Inspect all wire connections for discolored and/or burned wires. Replace where necessary.
4. Check unit for proper grounding.
5. Check and adjust the following items:
 - a. Open make-up water valve allowing sump to fill with water and check for leaks.
 - b. Check float for operation and adjust to maintain water level at 3-1/4" depth.
 - c. Check the sump water level is 1/2" below the overflow level and the low water level switch is closed. Clean any debris around the overflow intake.
 - d. Fully close bleed valve, then fully open it counting the revolutions. Set to 50% open. Check after the first month of operation and adjust if necessary to prevent solids from forming on the exchanger.
 - e. Direct evaporative module - Inspect media pads and replace per manufacturer's recommendations.
 - 1) Inspect at bottom of heat exchanger for complete water coverage. Should see a steady flow of water across the complete exchanger.
 - f. Indirect evaporative module - Inspect fan for vibration.
 - 1) Inspect at bottom of heat exchanger for complete water coverage. Should see a steady flow of water across the complete exchanger.
 - g. Follow 'Initial Start-Up' procedures. See attached.

Annual Shutdown for Winterizing

1. Disconnect power to unit.
2. Shut off manual water make-up valve to unit.
3. Drain sump (Pump removal is not necessary). Unplug pump. Use garden hose to flush out the sump and clean any debris or algae. For freeze protection, be sure that supply water is shut off inside and that the water line is sloped to allow complete draining of the line.

4. Indirect evaporative module - Wash primary heat exchanger passages with hot water and mild detergent if dirty. Clean the heat exchanger from the inside to outside direction to prevent water accumulation inside the unit.
5. Visually check wetted plates of exchanger on top (Vaporizer Exhaust Air Flow) and bottom for excess build-up of solids from evaporating water. If plates have more than 1/32" of white solids (calcium-lime), use vinegar or muriatic acid diluted to 10% to wash plates. Pour non-diluted vinegar over the top of the plates until solids dissolve, circulate and flush. Use a synthetic bristle brush to remove any scale at bottom of the plates.

⚠ WARNING:

If module is equipped with direct evaporative section, shut water balancing valve or sump pump to direct media.

⚠ WARNING:

Do not put vinegar or acid on direct media.

⚠ WARNING:

Do not operate vaporizer or supply fan when cleaning. Completely flush sump two times with clean water after cleaning. Obtain professional water treatment advice and increase bleed rate to reduce solids plating.

NOTE: A damaged or fouled Indirect Heat Exchanger can be replaced in most cases. Contact Cambridge Air Solutions for a replacement heat exchanger. See Troubleshooting section for instructions on media replacement.

6. Clean strainer.
7. Provide maintenance as recommended by the manufacturer of vaporizer fan and motor.
8. Drain coils that are not in use when subjected to freezing temperatures. Failure to do so may result in coil freeze up damage.

TROUBLESHOOTING

Water Carry Over Causes for Cambridge Air Solutions Direct and Indirect Evaporative Modules

The following items should be checked if there is water carryover in the Cambridge Air Solutions Evaporative Cooler modules of the unit. For detailed repair procedures, contact your local Sales Representative and refer to the manufacturer's literature.

- Distribution media (direct) or Mist Eliminator (indirect), both located on top of the heat exchanger, not properly installed or removed causing excessive splashing.
- Incorrect sprinkler or nozzle orientation.
- Too high flow rate through water distribution header.
- Media installed backwards.
- Fan CFM (velocity across pads) is too high.
- Improperly installed media allowing air to bypass media and entraining water on edges.
- Dirty/clogged media.
- Sagging media due to media breakdown from using deionized or distilled water or excessive mineral deposits creating breaches and allowing water carryover.
- Damaged plates (indirect) that leak water into the primary side of air flow. Leaks can be repaired with high quality non-silicone caulk (available from Cambridge Air Solutions).
- Vaporizer fans rotating backwards can cause excessive splashing as well as reduced cooling capacity.

SERVICES AVAILABLE

Factory trained technicians are available for start-ups.

Technical service support: Call 1-800-473-4569.

ORDERING

For prompt and accurate handling of your order, always include the following:

1. Owner and property location.
2. Date installed.
3. Cambridge Air Solutions Unit Model number.
4. Unit Serial number.
5. Part name or description.
6. Part number if available
7. Voltage of unit or part

ORDER NOTES

1. Photos of units/ sections or parts above will facilitate the identification and availability of the part(s).
2. Shipment may be delayed without proper information. If unit is still under warranty, replacement part(s) will be billed and shipped. Credit will be issued for both parts and shipping when the part(s) are returned, inspected, and found to be defective from normal usage.

Taxes: Any taxes or other government charges upon production, sale and /or shipment of merchandise sold hereunder, not imposed by Federal, State, or Municipal authorities, or hereafter becoming effective, shall be added to price herein provided, and shall be paid by the buyer.

PARTS LIST (COMMON PARTS USED):

Part #	Description
1. 9094-0004	Stainless steel sump pump
2. 9469-0002	Low water level switch
3. 9070-2004-05	½” Roberts float valve assembly
4. 9070-3003-05	Bleed valve
5. 9070-0006-08	Water balancing valve
6. 9401-4004	½ inch 3-way water fill valve
7. 9401-4003	2 inch 2-way water drain valve
8. 9401-4000	Fill and drain valve covers
9. 9477-0001-01	24 hour timer
10. 9477-0010	Time delay relay with base
11. 9470-0005	GFCI
12. 9506-0100	1 HP TEAO motor
13. 9506-0150	1.5 HP TEAO motor
14. 9506-0200	2 HP TEAO motor
15. 9506-0300	3 HP TEAO motor
16. 9250-0033	Multi-wing axial fan (2- Blade)
17. 9250-0031	Multi-wing axial fan (4- Blade)



**SCAN THIS CODE TO ACCESS OUR
“HOW-TO” SERVICE VIDEOS ONLINE.**

<https://www.cambridgeair.com/parts-service/how-to-service-videos>

Cambridge Air Solutions reserves the right to change specifications, modify the design and/or substitute equivalent materials without notice as the result of code requirements, product enhancements, ongoing research/development and vendor changes beyond our control.



760 Long Road Crossing Dr., Chesterfield, MO 63005
Phone: (636) 532-2233 (800) 899-1989, Fax: (636) 530-6133
www.cambridgeair.com