

# DIRECT GAS FIRED HEATING CH110 AGA and CH115 AGA TECHNICAL MANUAL

## **WARNING**

BEFORE OPERATING THIS APPLIANCE, READ, THOROUGHLY UNDERSTAND, AND FOLLOW THESE INSTALLATION, OPERATING AND MAINTENANCE INSTRUCTIONS. FAILURE TO DO SO CAN RESULT IN SERIOUS BODILY INJURY OR PROPERTY DAMAGE DUE TO THE HAZARDS OF FIRE, EXPLOSION, CARBON MONOXIDE POISONING OR ELECTRICAL SHOCK. RETAIN INSTRUCTIONS FOR FUTURE REFERENCE.

## **FOR YOUR SAFETY**

THE USE AND STORAGE OF GASOLINE OR OTHER FLAMMABLE VAPORS AND LIQUIDS IN OPEN CONTAINERS IN THE VICINITY OF THIS APPLIANCE IS HAZARDOUS.

## **FOR YOUR SAFETY**

IF YOU SMELL GAS:

1. OPEN WINDOWS.
2. DON'T TOUCH ELECTRICAL SWITCHES.
3. EXTINGUISH ANY OPEN FLAME.
4. IMMEDIATELY CALL YOUR GAS SUPPLIER.



## LIMITED WARRANTY

THE COMPANY WARRANTS ITS MANUFACTURED PRODUCTS TO BE FREE FROM DEFECTS IN MATERIAL AND WORKMANSHIP FOR A PERIOD OF TWELVE (12) MONTHS FROM DATE OF FIRST INSTALLATION, OR FIFTEEN (15) MONTHS FROM DATE OF SHIPMENT, WHICHEVER OCCURS FIRST, PROVIDED THE PRODUCT IS PROPERLY INSTALLED AND OPERATED UNDER NORMAL CONDITIONS IN ACCORDANCE WITH COMPANY'S OPERATION AND INSTALLATION INSTRUCTIONS AND LOCAL CODES.

MISUSE OR MISAPPLICATION OF THE PRODUCT FROM ITS ORIGINAL DESIGN OR SPECIFICATIONS, OR CHANGES IN ORIGINAL SPECIFICATIONS OR OPERATING CONDITIONS, WITHOUT WRITTEN PERMISSION FROM THE COMPANY SHALL VOID THIS WARRANTY.

THE COMPANY'S OBLIGATION HEREUNDER SHALL BE LIMITED TO THE REPAIR, OR AT ITS OPTION, REPLACEMENT OF DEFECTIVE PARTS RETURNED TO THE COMPANY'S FACTORY, TOGETHER WITH ORIGINAL SHOP ORDER REFERENCE AND SERIAL NUMBER OF HEATER. SHIPPING CHARGES SHOULD BE PREPAID. REPLACEMENT PARTS PROVIDED SHALL NOT EXTEND THIS WARRANTY FOR THE PART(S) OR PRODUCT(S). THE COMPANY SHALL HAVE NO RESPONSIBILITY UNDER THIS WARRANTY UNLESS AND UNTIL THE PRODUCT HAS BEEN PAID FOR IN FULL, ACCORDING TO TERMS OF SALES CONTRACT, AND THEN THE COMPANY'S LIABILITY SHALL BE LIMITED TO THE COST OF REPAIR, BUT IN NO CASE IN EXCESS OF THE ORIGINAL PURCHASE PRICE OF THE DEFECTIVE PRODUCT.

THE WARRANTY DOES NOT APPLY TO FIELD LABOR CHARGES OR TO PRODUCTS WHICH HAVE BEEN ABUSED, IMPROPERLY OPERATED, SUBJECTED TO ABNORMAL WEAR AND TEAR, DAMAGED AS A RESULT OF IMPROPER GAS OR ELECTRIC SERVICE, OR DAMAGED IN TRANSIT, OR BY MISUSE, NEGLIGENCE OR ACCIDENT, OR TO PRODUCTS WHICH HAVE BEEN REPAIRED OR MODIFIED WITHOUT AUTHORIZATION FROM THE COMPANY. THE COMPANY DOES NOT WARRANT PRODUCTS MANUFACTURED BY OTHERS. ANY CLAIMS WITH REGARD TO SUCH PRODUCTS MUST BE DIRECTED TO THE ORIGINAL MANUFACTURER.

THE COMPANY MAKES NO WARRANTY OTHER THAN STATED ABOVE. ALL OTHER WARRANTIES EXPRESS OR IMPLIED, INCLUDING ANY IMPLIED WARRANTIES REGARDING PERFORMANCE, APPLICATION OR FITNESS FOR A PARTICULAR PURPOSE, ARE HEREBY EXCLUDED AND DISCLAIMED. THE COMPANY ASSUMES NO LIABILITY FOR ANY INCIDENTAL, CONSEQUENTIAL, SPECIAL OR ECONOMIC DAMAGES UNDER ANY WARRANTY, EXPRESS OR IMPLIED OR OTHERWISE, AND ALL SUCH LIABILITY IS HEREBY EXPRESSLY EXCLUDED AND DISCLAIMED.

Cambridge Engineering, Inc.  
P.O. Box 1010  
Chesterfield, MO 63006

## INDEX

WARRANTY .....	Cover
HAZARD SUMMARY .....	2
ACCESSORY IDENTIFICATION .....	3
UNCRATING INSTRUCTIONS .....	3
THRU-THE-WALL APPLICATION & ILLUSTRATIONS.....	4-5
ROOF TOP APPLICATION & ILLUSTRATIONS.....	6-8
DOOR APPLICATION & ILLUSTRATIONS.....	9-13
ELECTRICAL INSTALLATION .....	14
ELECTRICAL DIAGRAMS .....	15-16
ELECTRICAL ISOMETRIC .....	17
GAS PIPING INSTALLATION .....	18-23
START-UP CHECK SHEET.....	24
START-UP PROCEDURES .....	25
MD, EDR CONTROL OPTION SUMMARY .....	26
EDS CONTROL OPTION SUMMARY .....	27
REMOTE CONTROL STATION OPERATION INSTRUCTIONS .....	27
REMOTE CONTROL STATION (RCS) .....	28
TEMPERATURE SETBACK SYSTEM (TSS).....	28
OPERATION OF THE TSS TIMER .....	29-31
OPERATION SEQUENCE (SINGLE SPEED MOTOR) .....	32
CONTROL SEQUENCE (SINGLE SPEED MOTOR) .....	33
OPERATION SEQUENCE (TWO SPEED MOTOR) .....	34
CONTROL SEQUENCE (TWO SPEED MOTOR) .....	35
INDIVIDUAL COMPONENT FUNCTIONS .....	36-39
DAMPER MOTOR .....	40
AUXILIARY SWITCH .....	40
TROUBLESHOOTING GUIDE .....	41-44
MAINTENANCE INSTRUCTIONS .....	45
BURNER CLEANING PROCEDURE .....	46
BURNER ISOMETRIC .....	47
UNIT ISOMETRIC DRAWING.....	48-49

Copyright, May 1989  
CAMBRIDGE ENGINEERING, INC.

## HAZARD SUMMARY

The following safety precautions apply to the installation, operation, and maintenance of the equipment described by this technical manual.

\*\*\*\*\* CAUTION \*\*\*\*\*

Only qualified personnel should attempt installation, service, and repair of this equipment. Use extreme caution and observe safety regulations at all times.

\*\*\*\*\*

**DO NOT RECIRCULATE IN THE FOLLOWING APPLICATIONS:**

1. **High Hazard Areas (Explosive Materials)**

Grain elevators, ammunition stores, paint spraying or storage, dry cleaning, or any process area using flammable solids, liquids or gases.

2. **Fluorinated Hydrocarbons (Toxic Substances)**

Areas where urethane foam is being used, or any area with concentrations of freons, refrigerants or aerosols.

\*\*\*\*\* WARNING \*\*\*\*\*

Any unauthorized modifications to this equipment may void warranty.

Direct gas-fired recirculation requires minimum of 4 CFM of fresh air ventilation per 1000 BTU/Hour of heat input.

Recirculation is not recommended in an uninsulated building where outside temperatures fall below 32° F.

\*\*\*\*\*

\*\*\*\*\* NOTE \*\*\*\*\*

Factory service information available. If in doubt regarding installation application, contact Cambridge Systems Service Department at (314) 532-2233.

\*\*\*\*\*

## ACCESSORY IDENTIFICATION

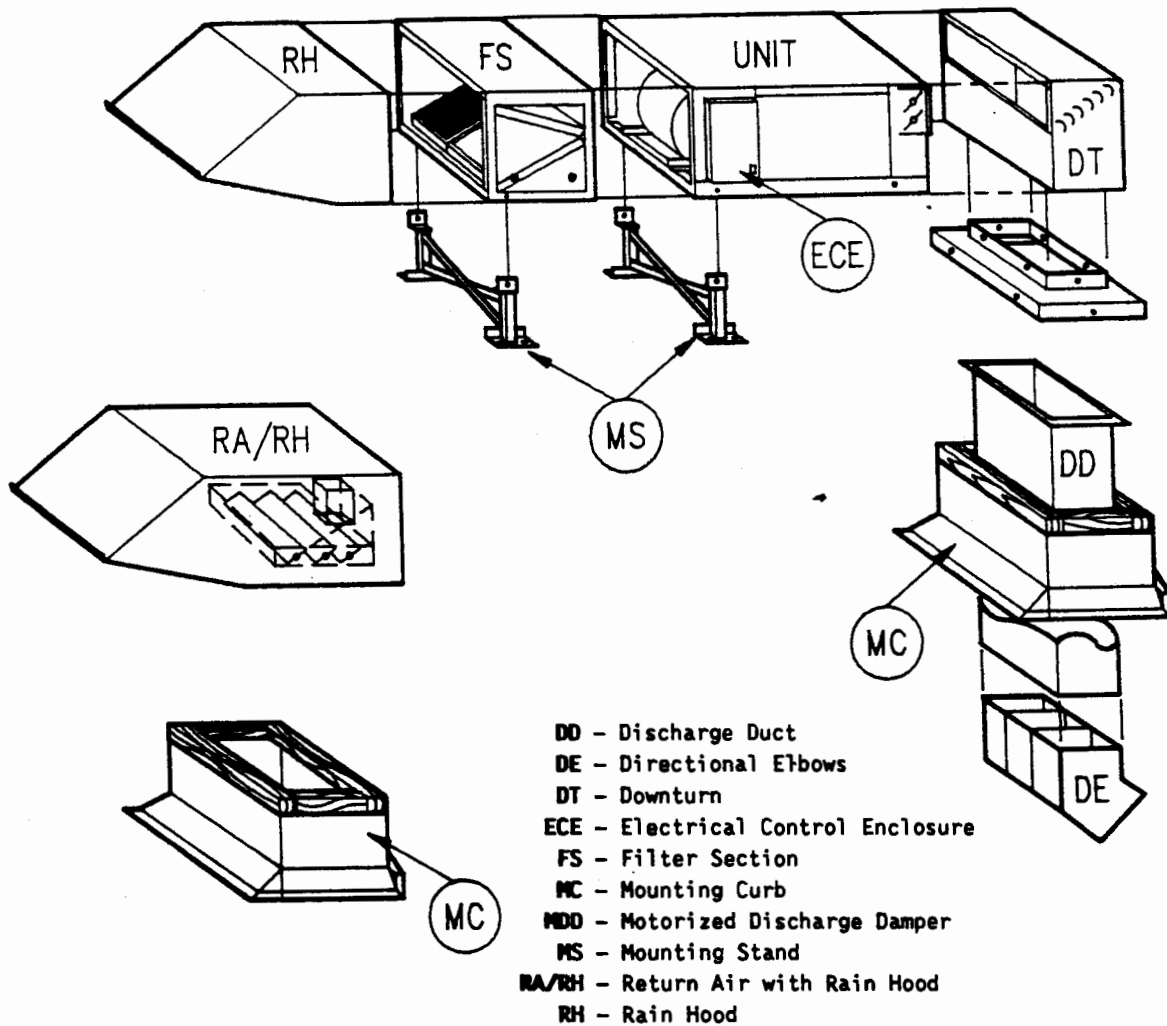

## UNCRATING INSTRUCTIONS

- Verify number of items shipped with number of items received.
- Remove items from shipping cartons and check for damage.
- If damage in transit is found, notify carrier immediately for claim.
- Check items received and verify data on nameplates to make sure it agrees with ordering information.
- Remove lag bolts fastening unit to skid. Do not remove "L" Brackets from side of unit. Do not remove unit from skid at this time.
- Do not discard any components and accessories or make any unauthorized substitutions.

# INSTALLATION INSTRUCTIONS: THRU-THE-WALL APPLICATION

## -READ CAREFULLY-

Before proceeding with installation, verify feasibility of location and allow for convenient access and serviceability of equipment. Recommended mounting height is 12' to 16' from floor to bottom of unit.

\*\*\*\*\* NOTE \*\*\*\*\*

If feasible, allow equipment to remain on skid during this entire process and until such time as it is fully secured in its final location.

Accurate measurements are critical and will affect installation process.

\*\*\*\*\*

- a. Wall opening should be a minimum of 26 1/2" high x 26 1/2" wide for the CH110AGA and 26 1/2" high x 36" wide for the CH115AGA.
- b. Install hanging rods (3/8" diameter threaded rod) to adequate ceiling supports and align with hanging brackets on unit. Note: Rain hood is to protrude at least 37" from outside surface of wall to rain gutter on front of hood. Make sure drain holes clear outside wall by at least 1".
- c. Check all accessory items to make sure they have been fastened securely. Loosen bolts on side of unit that secure "L" Brackets, invert "L" Brackets and retighten bolts.
- d. Use forklift or comparable lifting device to raise and position equipment. Block unit where necessary to prevent damage. Approximate weight of unit is 350 pounds for the CH110AGA; 650 pounds for the CH115AGA.
- e. Apply washer and lock nuts (contractor item) to secure equipment on hanging rods. Note: Discharge end of unit should be raised slightly (1/8" above level) to slope rain hood so exterior moisture will run away from building.
- f. Apply shims at bottom of rain hood to take up slack in opening. This should provide small joint between top of unit and wall.
- g. Install fiberglass insulation in gaps around wall opening and rain hood. Apply enough material to accommodate full thickness of wall.
- h. Install finish trim pieces to top, sides and bottom of rain hood and outside wall surface (contractor supplied). Trim inside of opening in same manner.
- i. Apply bead of silicone caulking (G.E. or equivalent) at joint between top of rain hood and outside wall surface. Make certain this is a continuous bead and that it runs entire width of hood. Caulk other joints as required.
- j. Install directional elbows or grilles on downturn. Choose configuration to best suit application. See sketch on Page 5.

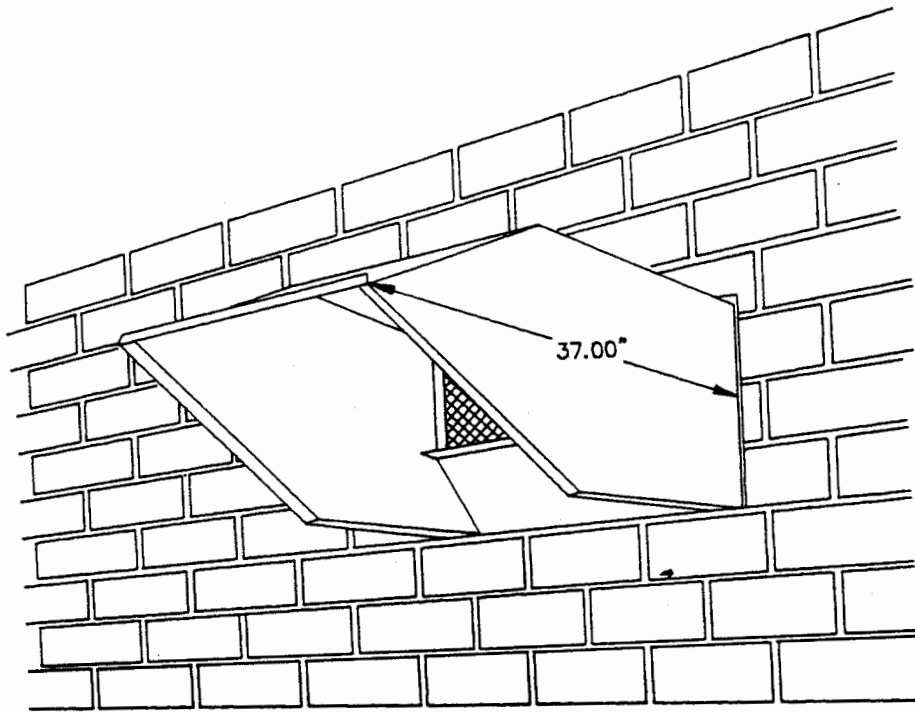

**TYPICAL CH110AGA - CH115AGA  
THROUGH WALL INSTALLATION**

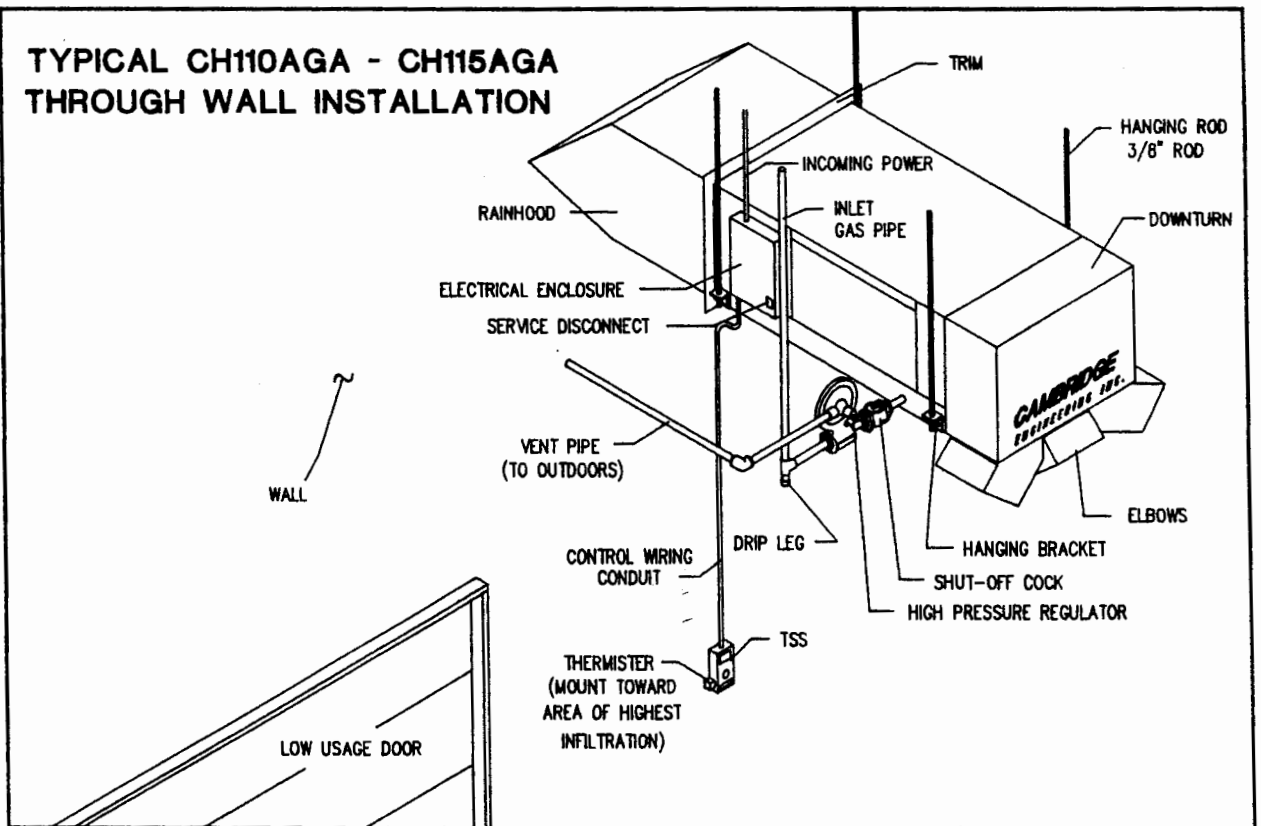

# MOUNTING INSTRUCTIONS: ROOF TOP INSTALLATION

-READ CAREFULLY-

Before proceeding with installation, verify feasibility of location and allow for convenient access and serviceability of equipment.

\*\*\*\*\* NOTE \*\*\*\*\*

Accurate measurements are critical and will affect installation process.

\*\*\*\*\*

- a. Install roof supports. See sketches for mounting options and dimensions.
- b. Remove "L" Brackets from side of unit and use same bolts to install unit to mounting stands (when applicable).
- c. Check all accessory items to make sure they have been fastened securely.
- d. Use crane or comparable lifting device to raise and position equipment. Block unit where necessary to prevent damage. Approximate weight of unit is 350 pounds for the CH110AGA; 650 pounds for the CH115AGA.
- e. Secure unit to roof supports.
- f. Caulk all joints on unit and accessories to prevent water leaks.
- g. Apply roof tar around areas of penetration to prevent roof leaks.



# CH110AGA ROOF TOP INSTALLATION

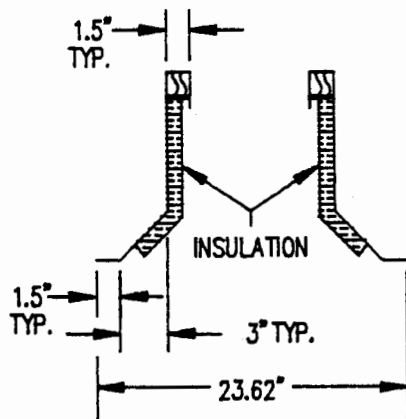
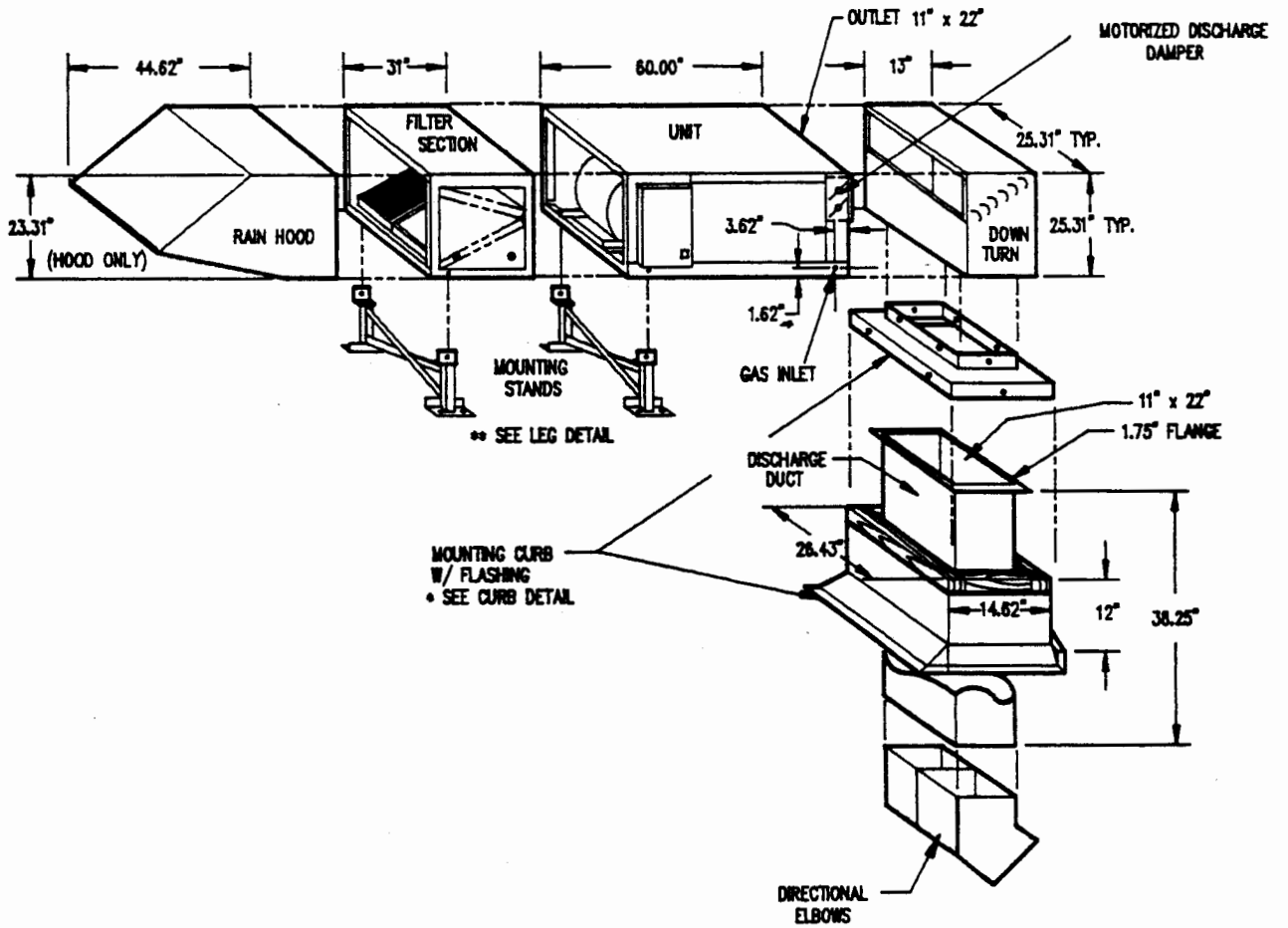

DISCHARGE CURB

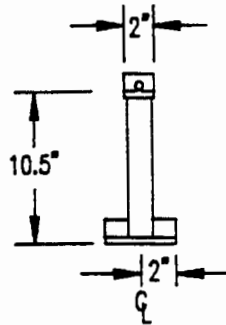

\*\* LEG DETAIL

# CH115AGA ROOF TOP INSTALLATION

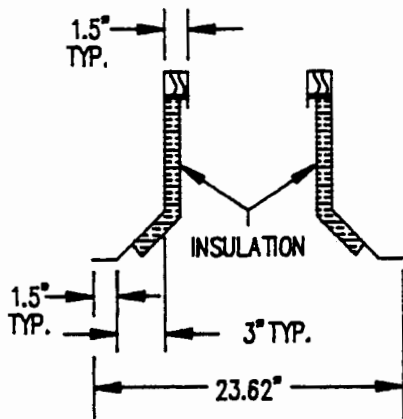
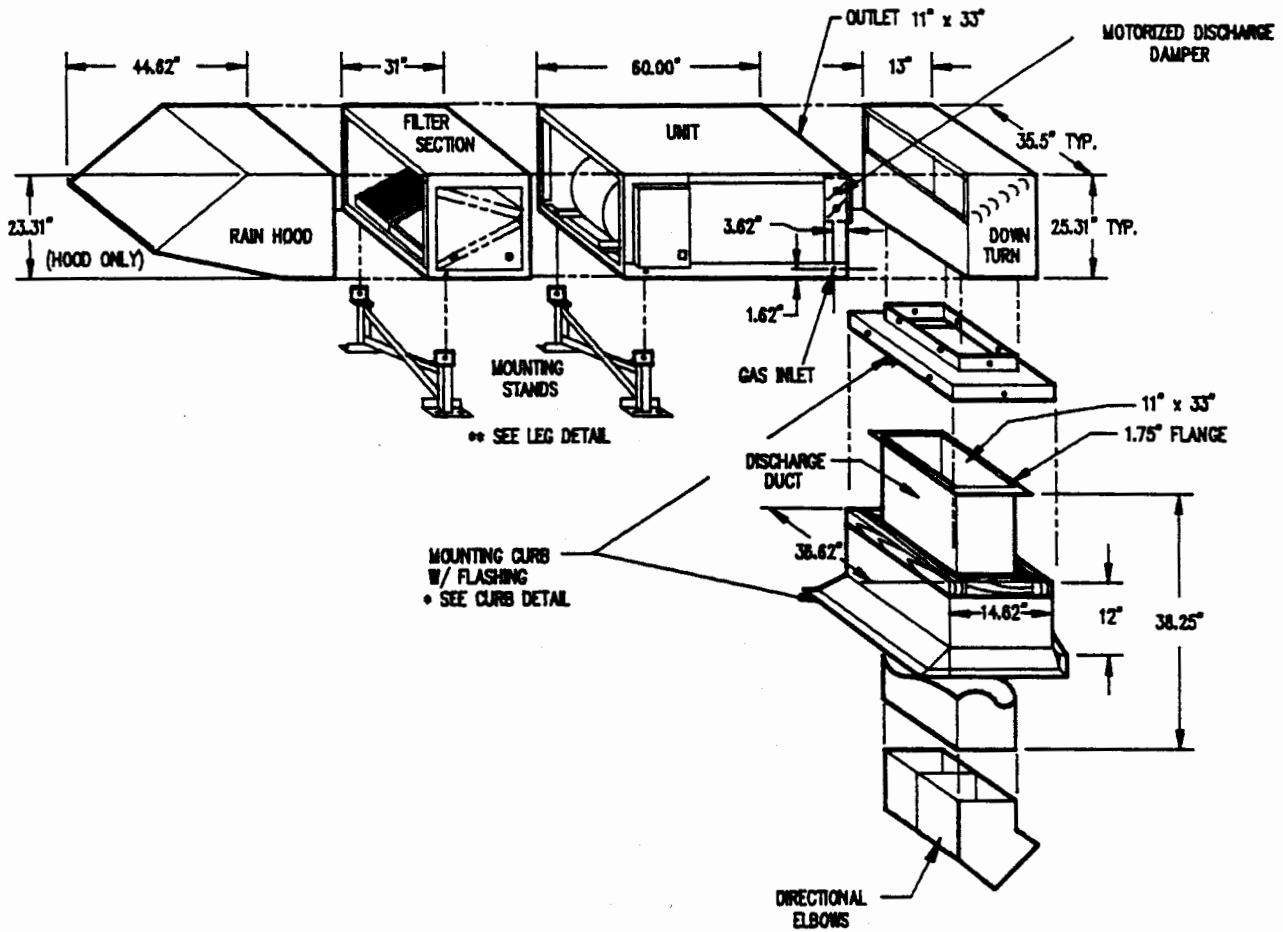

DISCHARGE CURB

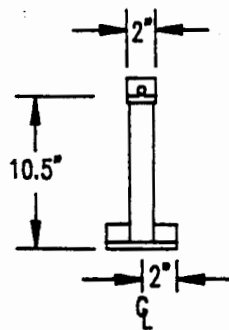

•• LEG DETAIL

# INSTALLATION INSTRUCTIONS: DOOR APPLICATION

-READ CAREFULLY-

Before proceeding with installation, verify feasibility of location and allow for convenient access and serviceability of equipment.

\* \* \* \* \* NOTE \* \* \* \* \*

Equipment is to remain on skid until such time it is fully secured in its final location.

Accurate measurements are critical and will affect installation process.

\* \* \* \* \*

- a. Install hanging rod (3/8" diameter threaded rod) to adequate ceiling supports. These rods to align with hanging brackets on unit or unit support beams. Note: Maintain a clearance of 12" to 20" between inside wall surface and rear of unit. If hanging rods connect directly to unit, loosen "L" angles, invert, and retighten. If support beams (contractor supplied) are utilized, bolt unit to beams through "L" angles. Refer to drawings on next four pages for more detailed information.
- b. Check all accessory items to make sure they have been fastened securely. Check hanging brackets and make sure they have been properly fastened and positioned.
- c. Use forklift or comparable lifting device to raise and position equipment. Block unit where necessary to prevent damage. Approximate weight of unit is 350 pounds for the CH110AGA and 650 pounds for the CH115AGA.
- d. Apply washer and lock nuts (contractor item) to secure equipment on hanging rods.
- e. Whenever feasible, install stabilizing brackets from unit to wall (contractor item).
- f. A door switch must be utilized as the controlling device for door units. This switch should be installed such that it will activate heater when door is opened and shut unit off when door is closed.

CH110AGA  
L" ANGLE AND HANGING ROD INSTALLATION

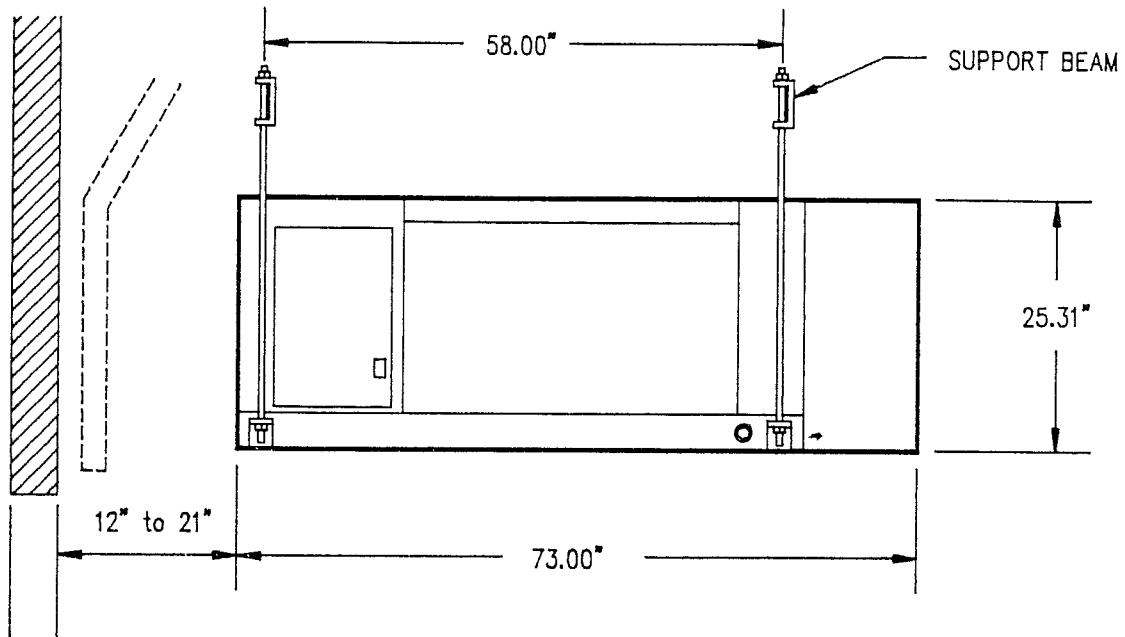

**SIDE VIEW**

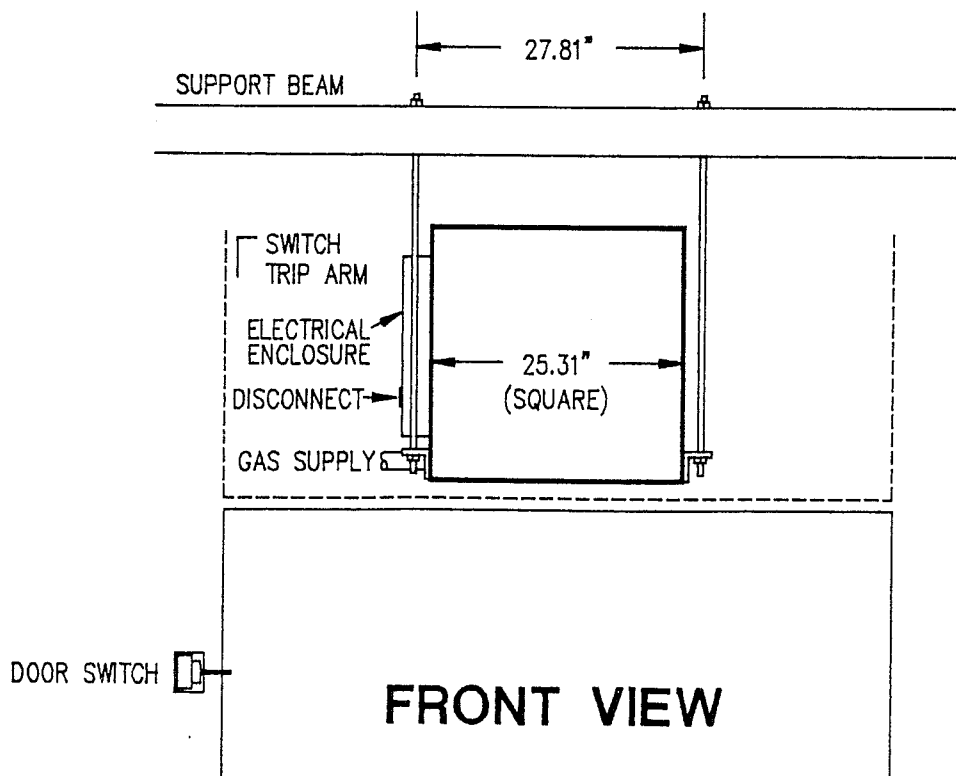

**FRONT VIEW**

CH110AGA  
TYPICAL SUPPORT BEAM INSTALLATION

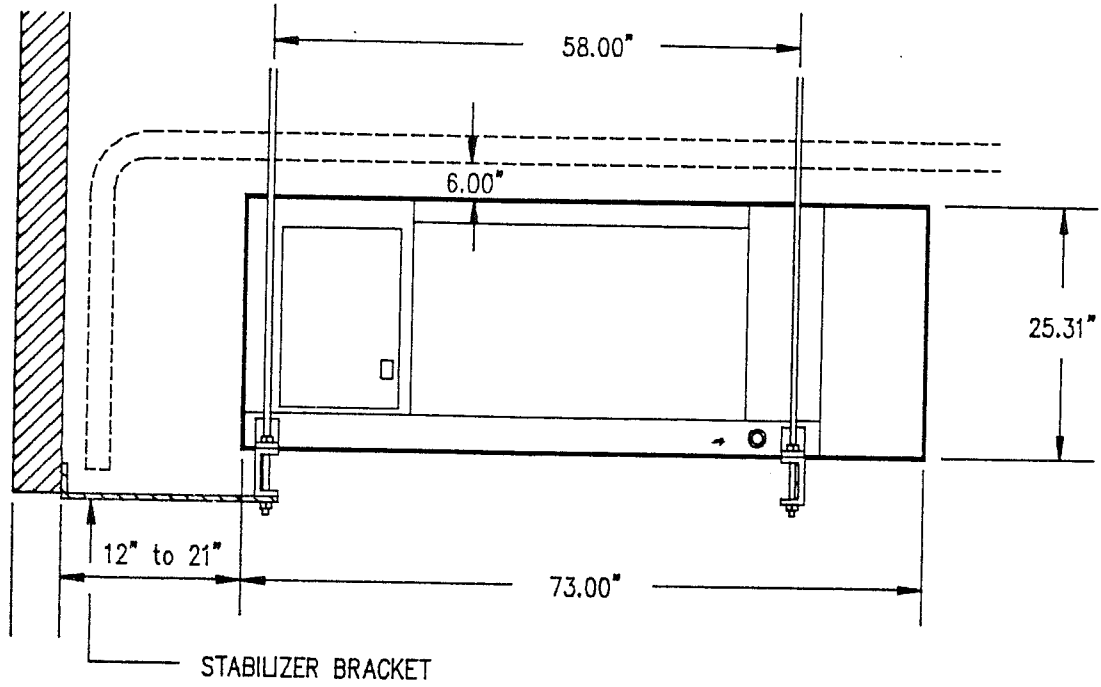

**SIDE VIEW**

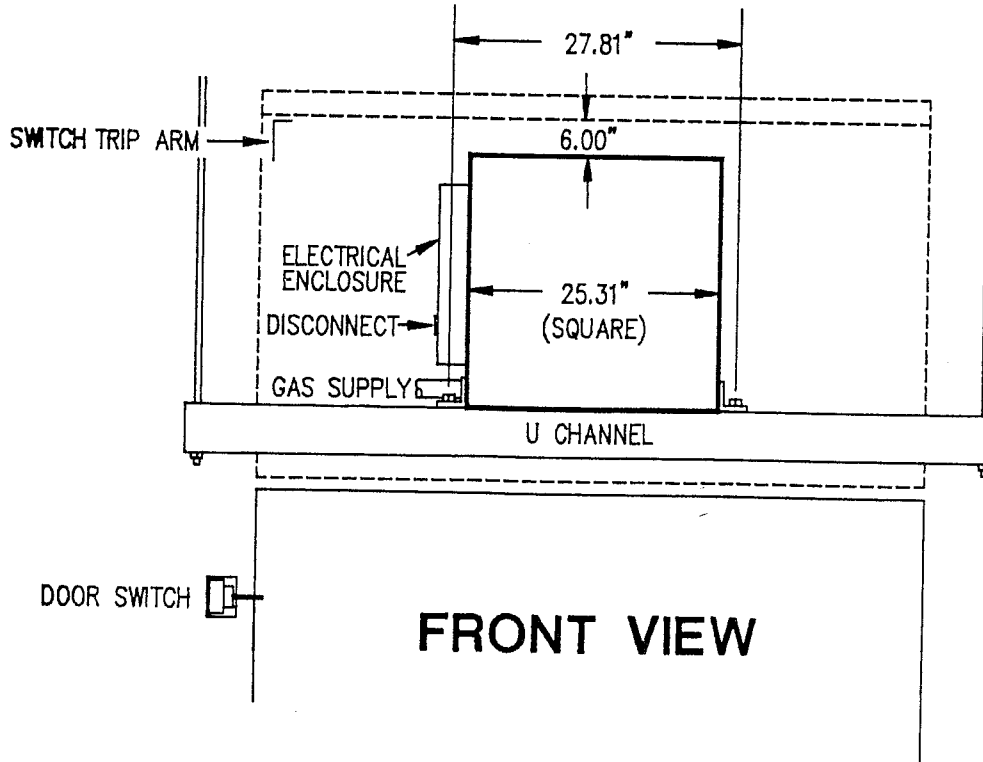

**FRONT VIEW**

CH115AGA  
L" ANGLE AND HANGING ROD INSTALLATION

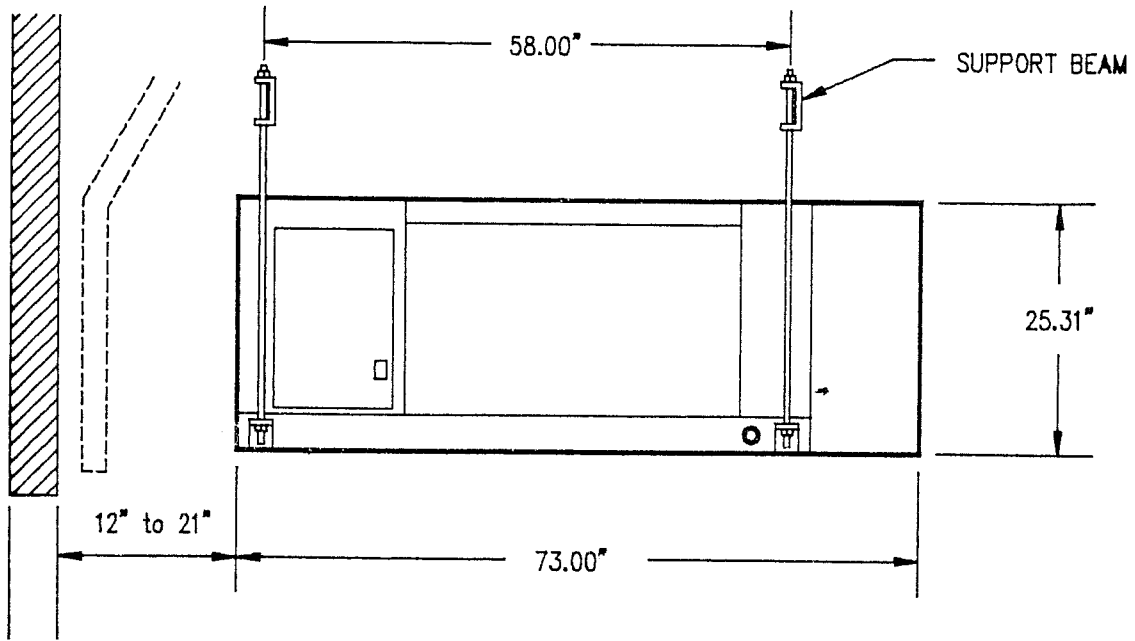

**SIDE VIEW**

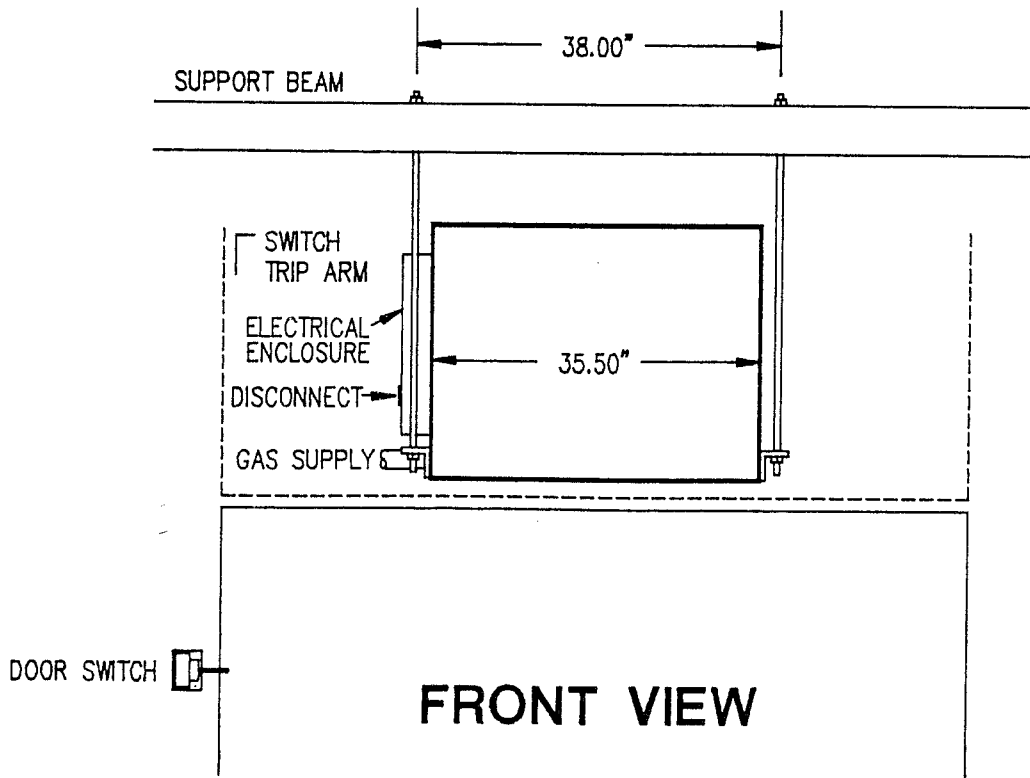

**FRONT VIEW**

CH115AGA  
TYPICAL SUPPORT BEAM INSTALLATION

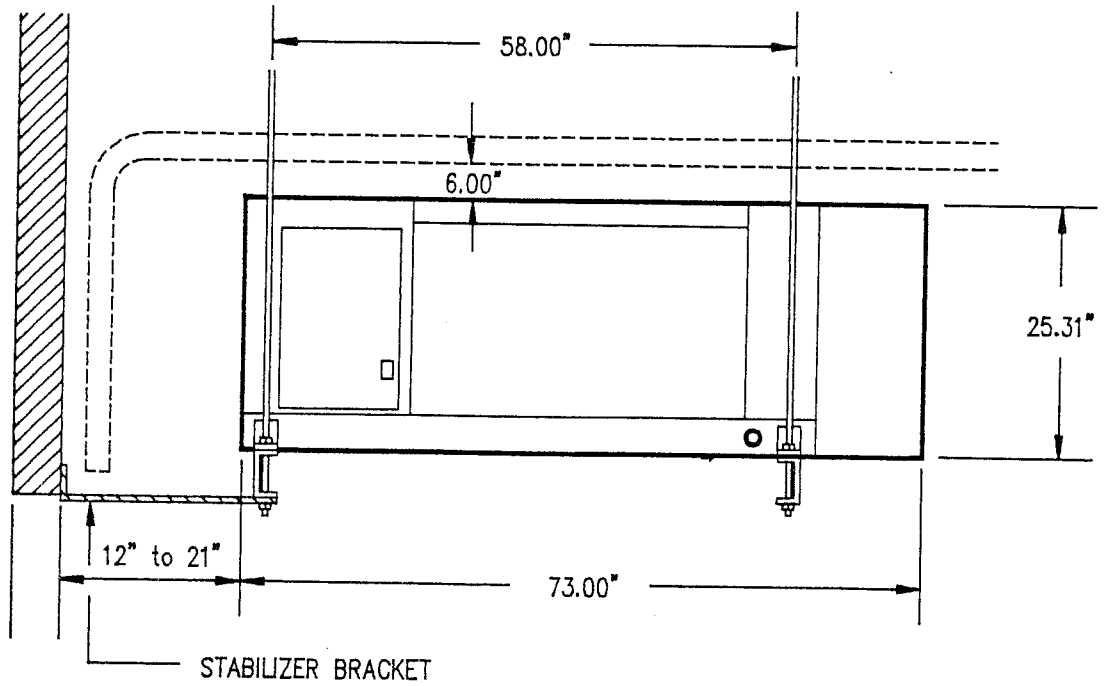

**SIDE VIEW**

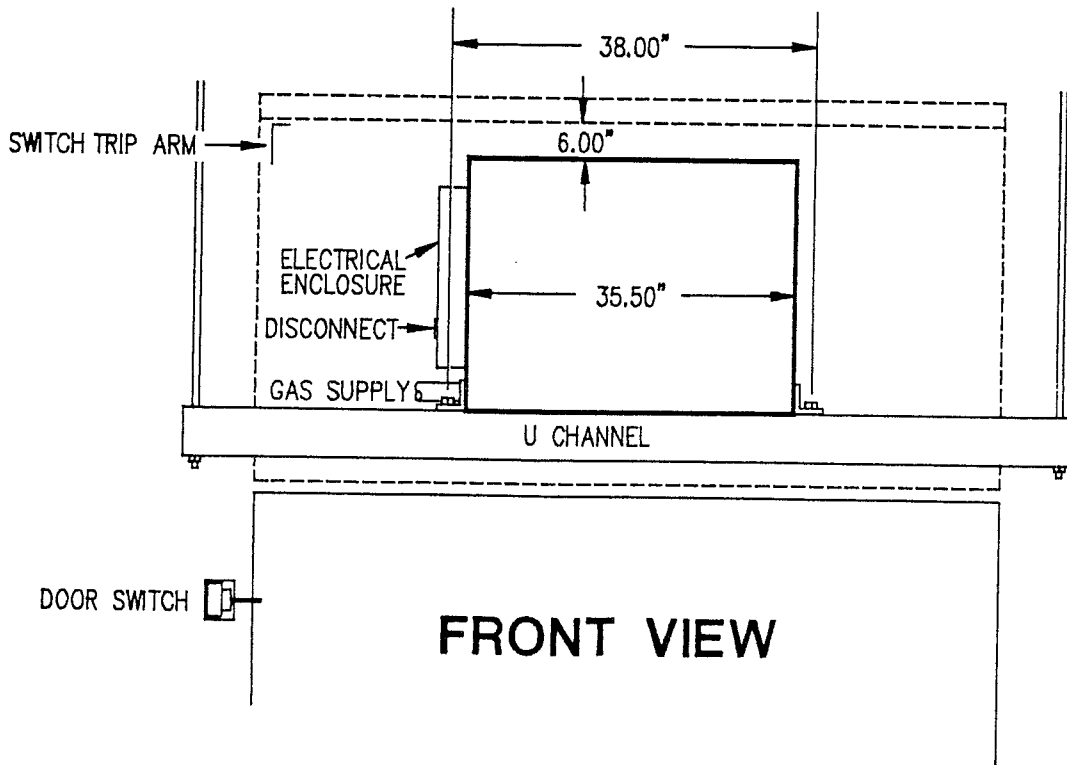

**FRONT VIEW**

## INSTALLATION INSTRUCTIONS: ELECTRICAL

Before attempting electrical installation, review following instructions and wiring diagrams to make sure you have a thorough understanding of what is required.

\*\*\*\*\* WARNING \*\*\*\*\*

High voltage electrical input to this equipment is required. Extreme caution should be exercised.

This equipment must be electrically grounded in accordance with local codes or in accordance with National Electrical Code ANSI/NFPA No. 70-1987.

\*\*\*\*\*

- a. Check nameplate on side of unit to determine voltage and amperage requirements of equipment.
- b. Supply proper wiring and adequate Branch Circuit Protection in accordance with the N.E.C. ANSI/NFPA 70-1987.
- c. Mount Remote Control Station (RCS). This control should be located inside of building and convenient to operator without being susceptible to damage.
- d. The following instruction is applicable to units having Operating Thermostat (OT), Space Thermostat (ST), or temperature setback options.

Locate all thermostats in the highest infiltrated area and out of the direct line of discharge air currents.

- e. Wire Remote Control Station and other temperature control options (using Class II Wiring) per Cambridge wiring diagram and N.E.C. Article 725.

\*\*\*\*\* CAUTION \*\*\*\*\*

Observe special notes and instructions on wiring diagrams.

\*\*\*\*\*

- f. Run conduit and primary wiring to disconnect switch inside of control cabinet on unit. (Per N.E.C., Article 430, ANSI/NFPA 70-1987.)

\*\*\*\*\* WARNING \*\*\*\*\*

Do not attempt to start unit at this time. Premature start-up can result in damage to equipment and components.

\*\*\*\*\*

- g. Return wiring diagram to the manual holder.  
Replace and fasten all access covers and panels.





ELECTRIC SCHEMATIC FOR A  
CH15AGA (HC) UNIT  
120V GAS VALVE  
401MBH and ABOVE (NAT. GAS ONLY)  
EDS CONTROLS

CHESTERFIELD, MISSOURI

NO. DATE  
BY MNS DATE 6 / 8 / 89

THIS DRAWING IS AN INSTRUMENT OF SERVICE AND IS THE SOLE PROPERTY OF CAMBRIDGE ENGINEERING, INC. IT MAY NOT BE COPIED, REPRODUCED OR REUSED WITHOUT AGREEMENT IN WRITING FROM THIS COMPANY.

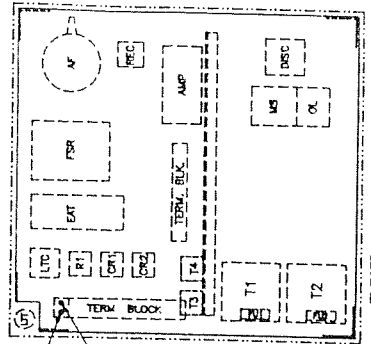
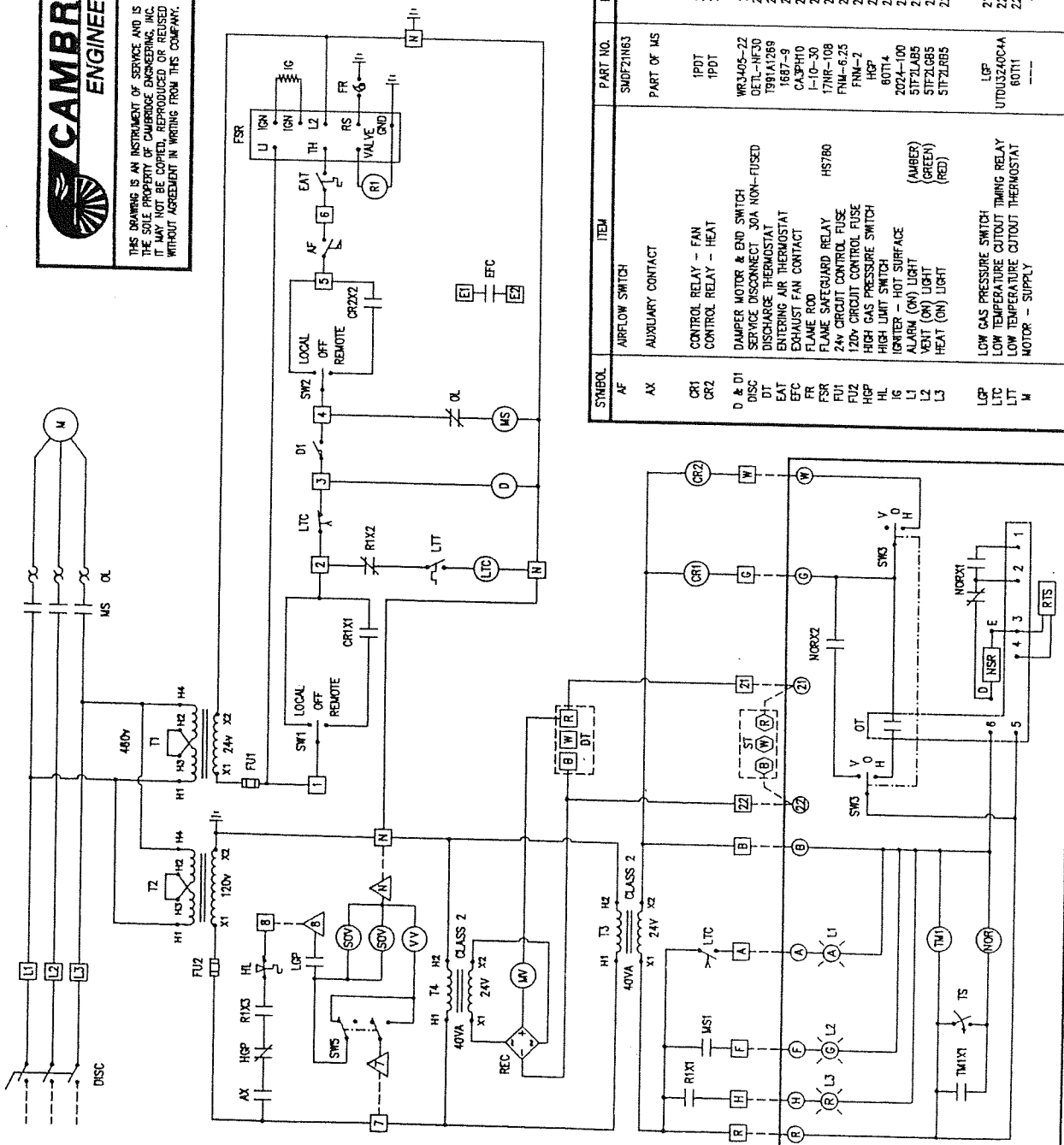

UNIT AMPS	MOTOR SIZE
INPUT POWER	2 HP 3 HP 5 HP
480V 3PH	3.9A 5.3A 8.1A

SYMBOL	ITEM	PART NO.	INV. NO.
AF	AIRFLOW SWITCH	SMDPZ1NE3	21-080
AX	AUXILIARY CONTACT	PART OF MS	
CR1	CONTROL RELAY - FAN	1PDT	22-921
CR2	CONTROL RELAY - HEAT	1PDT	22-922
D & DI	DAMPER MOTOR & END SWITCH	WR340S-22	23-101
DISC	SERVICE DISCONNECT 30A NON-FUSED	DET-NE30	22-678
DT	DISCHARGE THERMOSTAT	T891A1268	23-032
EAT	ENTERING AIR THERMOSTAT	1687-9	23-022
EFC	EXHAUST FAN CONTACT	CA3PH10	23-435
FR	FLAME ROD	L-10-30	21-082
FSR	FLAME SAFEGUARD RELAY	17NR-108	21-082
FU1	24V CIRCUIT CONTROL FUSE	FNM-6.25	22-019
FU2	120V CIRCUIT CONTROL FUSE	FNM-2	22-010
HSP	HIGH GAS PRESSURE SWITCH	HSP	21-057
HL	HIGH LIGHT SWITCH	80T14	23-100
IG	IGNITER - HOT SURFACE	2024-100	21-083
LI	ALARM (ON) LIGHT	5TFZLAB5	22-600
LZ	VENT (ON) LIGHT	5TFZLAB5	22-601
L3	HEAT (ON) LIGHT	5TFZLRB5	22-602
LGP	LOW GAS PRESSURE SWITCH	LGP	21-056
LTC	LOW TEMPERATURE CUTOFF TIMING RELAY	UTDU3240CA4	22-605
LTT	LOW TEMPERATURE CUTOFF THERMOSTAT	80T11	22-675
M	MOTOR - SUPPLY		
MS	MOTOR STARTER	CA3-9/12/16	22-604/086/610

SYMBOL	ITEM	PART NO.	INV. NO.
MS1	AUX. CONTACT	CA3-PH10	22-435
MV	MODULATING GAS VALVE	M611	24-033
OL	OVERLOAD RELAY & CONTACTS	CT3K	22-415/A24
NOR	NIGHT OVERRIDE RELAY	3PDT	22-295
NOR	NIGHT OVERRIDE RELAY	1 SET	22-479
OT	OPERATING THERMOSTAT	SP-33	23-062
RI	CONTROL RELAY	3PDT	22-295
REC	THERMOSTAT CIRCUIT RECTIFIER	200V/25A	22-474
RTS	REMOTE TEMPERATURE SELECTOR	PART OF OT	
SOV	SHUT-OFF VALVE (GAS)	V4055A1031	23-037
ST	SPACE THERMOSTAT	T891A1508	23-005
SW1	SERVICE VENT LOCAL/OFF/REMOTE	SPDT C/O	23-040
SW2	SERVICE HEAT LOCAL/OFF/REMOTE	SPDT C/O	23-040
SW3	VENT/OFF/HEAT SWITCH (KEY LOCK)	3 POS C/O	22-468
SW5	LEAK TEST SWITCH	DPTD (4)	22-384
T1	MULTI-TAP TRANSFORMER	1500va	23-528
T2	MULTI-TAP TRANSFORMER	1500va	22-671
T3	CLASS 2 TRANSFORMER	40VA	22-678
T4	CLASS 2 TRANSFORMER	40VA	23-078
TMI	NIGHT SETBACK TIME CLOCK	1W-2	23-102
TS	NIGHT SETBACK OVERRIDE TIMER SWITCH	90.000	22-467
VV	VENT VALVE	8215A033	21-028



ELECTRIC SCHEMATIC FOR A  
 CH115AGA (LC) UNIT  
 24V GAS VALVE  
 400MBH and BELOW (NAT. GAS & LP)  
 EDS CONTROLS

CHESTERFIELD, MISSOURI

NO.	DATE	NO.	DATE
REVISION			

BY: MNS DATE: 6/6/89

THIS DRAWING IS AN INSTRUMENT OF SERVICE AND IS THE SOLE PROPERTY OF CAMBRIDGE ENGINEERING, INC. IT IS NOT TO BE COPIED, REPRODUCED OR REDUCED WITHOUT AGREEMENT IN WRITING FROM THIS COMPANY.

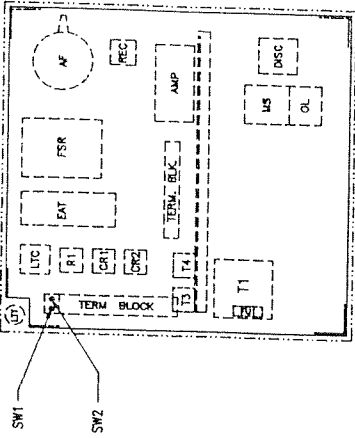
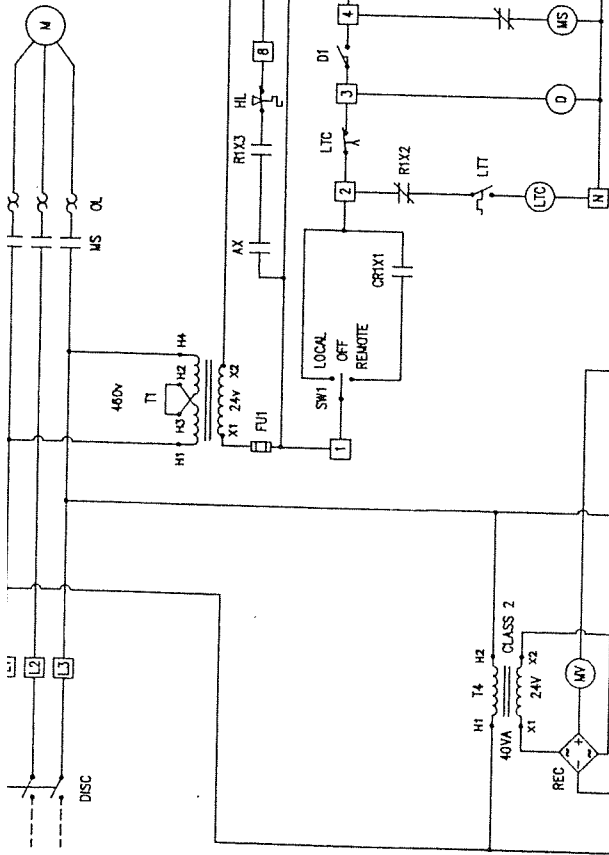

ELECTRICAL CONTROL ENCLOSURE

UNIT AMPS	MOTOR SIZE
INPUT POWER	2 HP 3 HP 5 HP
460V 3PH	3.9A 5.3A 8.1A

SYMBOL	ITEM	PART NO.	INV. NO.
MS1	AUX. CONTACT	CA3-PH10	22-435
MS1	MODULATING GAS VALVE	MS11	24-033
MS1	OVERLOAD RELAY & CONTACTS	OTCK	22-415/424
MS1	NIGHT OVERRIDE RELAY	JPDT	22-285
MS1	NIGHT SETBACK RESISTOR	1 SET	22-479
MS1	OPERATING THERMOSTAT	SP-33	23-062
MS1	CONTROL RELAY	JPDT	22-285
MS1	THERMOSTAT CIRCUIT RECTIFIER	200V/25A	22-474
MS1	REMOTE TEMPERATURE SELECTOR	PART OF OT	---
MS1	SHUT-OFF VALVE (GAS)	36C68	24-104
MS1	SPACE THERMOSTAT	T921A1508	23-005
MS1	SERVICE VENT LOCAL/OFF/REMOTE	SPDT C/O	22-040
MS1	SERVICE HEAT LOCAL/OFF/REMOTE	SPDT C/O	22-040
MS1	VENT/OFF/HEAT SWITCH (KEY LOCK)	3 POS C/O	22-486
MS1	MULTI-TAP TRANSFORMER	150va	22-628
MS1	CLASS 2 TRANSFORMER	40va	22-684
MS1	CLASS 2 TRANSFORMER	40va	22-884
MS1	NIGHT SETBACK TIME CLOCK	TM-2	23-102
MS1	NIGHT SETBACK OVERRIDE TIMER SWITCH	90,000	22-477

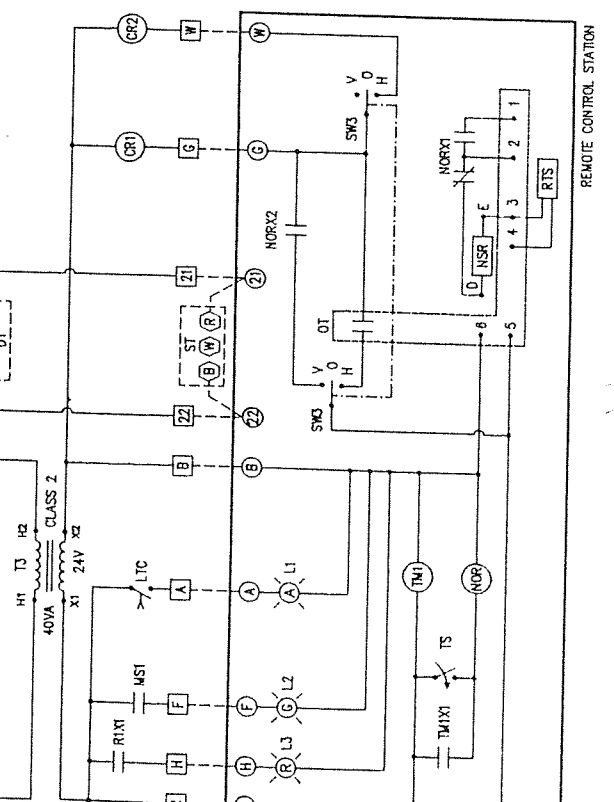

# ELECTRICAL CONTROL ENCLOSURE ISOMETRIC DRAWING

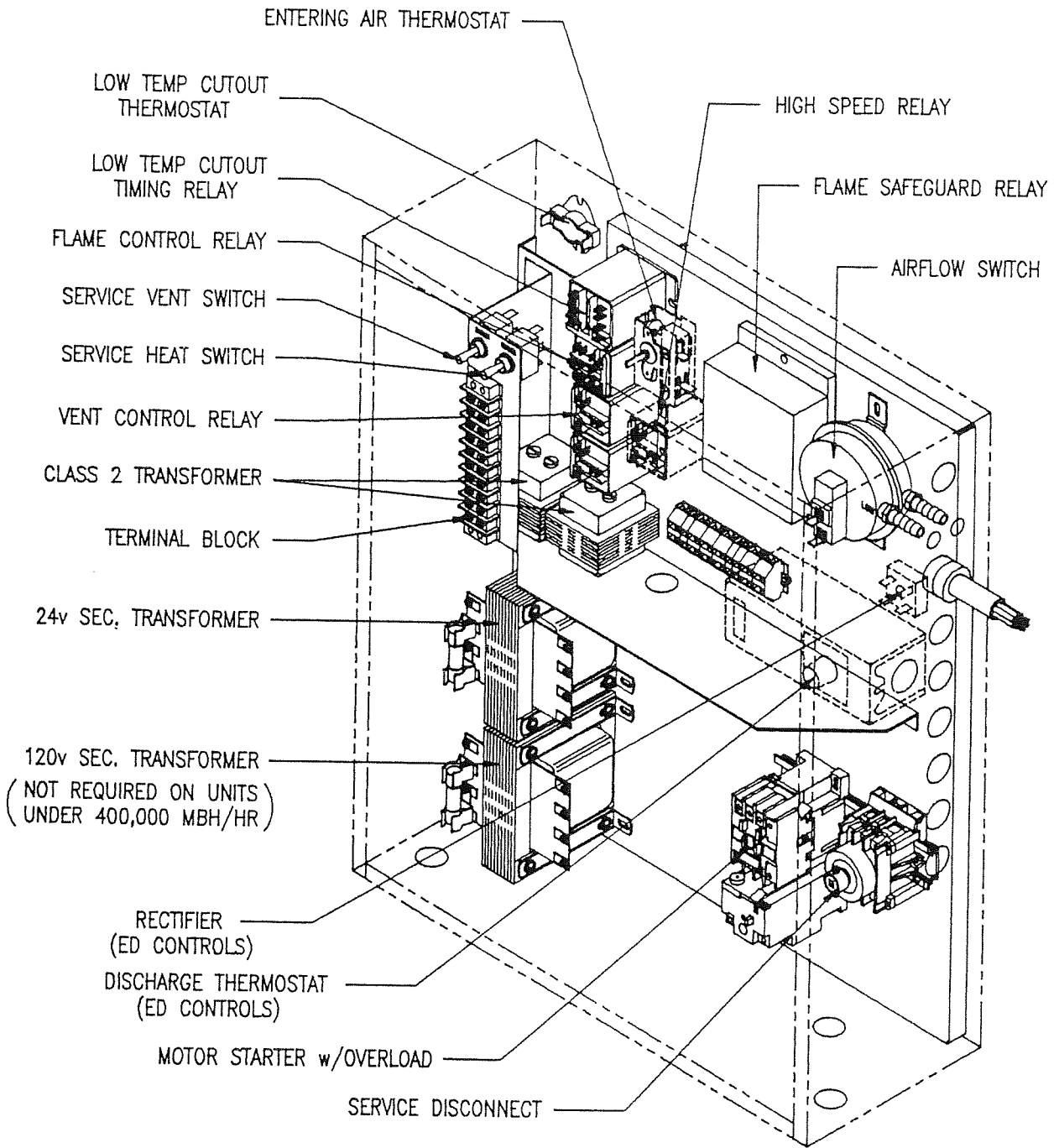

INSTALLATION INSTRUCTIONS: GAS PIPING

\*\*\*\*\* NOTE \*\*\*\*\*

Refer to nameplate on side of unit to determine gas supply requirements.

If supply pressure is in excess of 14" w.c., a separate positive shutoff high pressure regulator must be added upstream of the unit's individual shutoff valve. This regulator must be vented to outside of building with no reduction in size of the vent piping. Check with local utility or gas supplier for gas supply pressure.

\*\*\*\*\*

- a. Run piping to unit and secure per National Fuel Gas Code.

\*\*\*\*\* NOTE \*\*\*\*\*

A 1/8" N.P.T. tap accessible for manometer connection must be installed immediately upstream of the gas supply connection to the heater. An adequate drip leg must be installed as close to the inlet of the heater as practical. The piping must be properly sized for rated capacity, per local codes, or the National Fuel Gas Code, ANSI Z223.1-1984.

\*\*\*\*\*

- b. Check for leaks in supply piping system. Use liquid gas detector.

\*\*\*\*\* CAUTION \*\*\*\*\*

If the test pressure is in excess of 1/2 PSIG (3.45 KPA), the heater and its manual shutoff valve must be disconnected from the gas supply system during pressure testing.

If the test pressure is less than or equal to 1/2 PSIG (3.45 KPA), the heater must be isolated from the gas supply piping by closing its manual shutoff valve during pressure testing.

Make sure all supply piping is free of foreign matter and purged.

Do not attempt to start unit at this time. Premature start-up can result in damage to equipment and components.

\*\*\*\*\*

CH110/115AGA  
MD PIPING SCHEMATIC  
(UNDER 400 MBH)

NO.	ITEM	QTY.
1	ELBOW - BLK PIPE	2
2	NIPPLE - BLK PIPE	1
3	UNION - BLK PIPE	1
4	NIPPLE - BLK PIPE	2
5	VALVE - GAS HSOV	1
6	NIPPLE - BLK PIPE	1
7	VALVE - GAS MODULATING	1
8	NIPPLE - BLK PIPE	1
9	VALVE - COMB. REG & SOV (MOD.)	1
10	NIPPLE - BLK PIPE	1
11	ELBOW - BLK PIPE	1
12	NIPPLE - BLK PIPE	1
13	UNION - BLK PIPE	1
14	NIPPLE - BLK PIPE	1
15	VALVE - GAS HSOV	1
16	SEALER * PIPE	.042

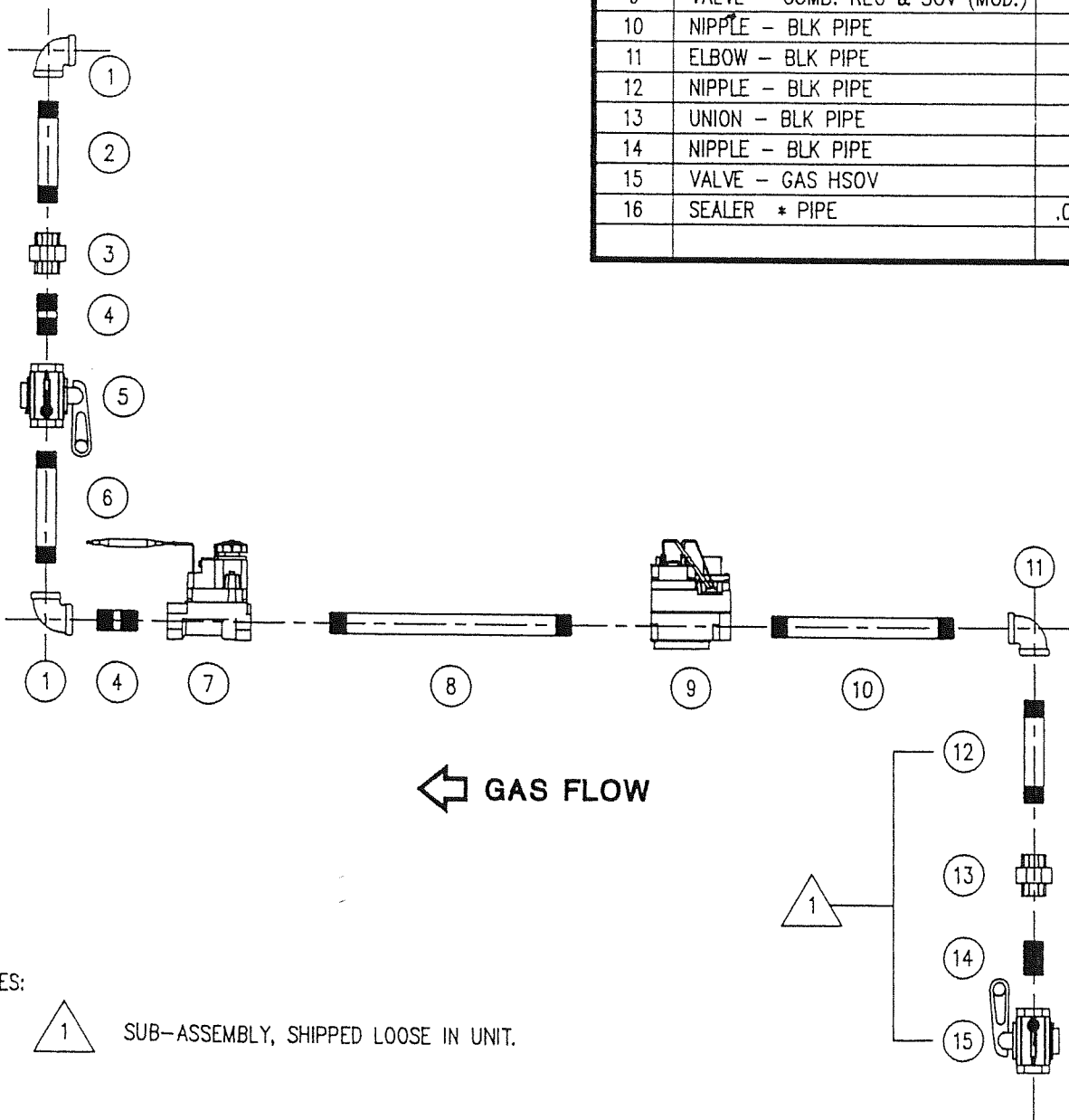

NOTES:

△ 1 SUB-ASSEMBLY, SHIPPED LOOSE IN UNIT.

CH110/115AGA  
 MD PIPING SCHEMATIC  
 (OVER 400 MBH)

NO.	ITEM	QTY.
1	ELBOW - BLK PIPE	1
2	NIPPLE - BLK PIPE	2
3	UNION - BLK PIPE	2
4	NIPPLE - BLK PIPE	2
5	VALVE - GAS HSOV	2
6	NIPPLE - BLK PIPE	1
7	ELBOW - BLK PIPE	2
8	NIPPLE - BLK PIPE	3
9	VALVE - GAS MODULATING	1
10	NIPPLE - BLK PIPE	1
11	VALVE - GAS ELECTRIC 0.5#	1
12	NIPPLE - W/TAP 1/8"NPT	1
13	NIPPLE - BLK PIPE	1
14	ELBOW - BLK PIPE	1
15	PLUG - BLK PIPE	1
16	VALVE - GAS ELECTRIC 5.0#	1
17	REGULATOR - W/BL SPRG	1
18	SEALER * PIPE	.042

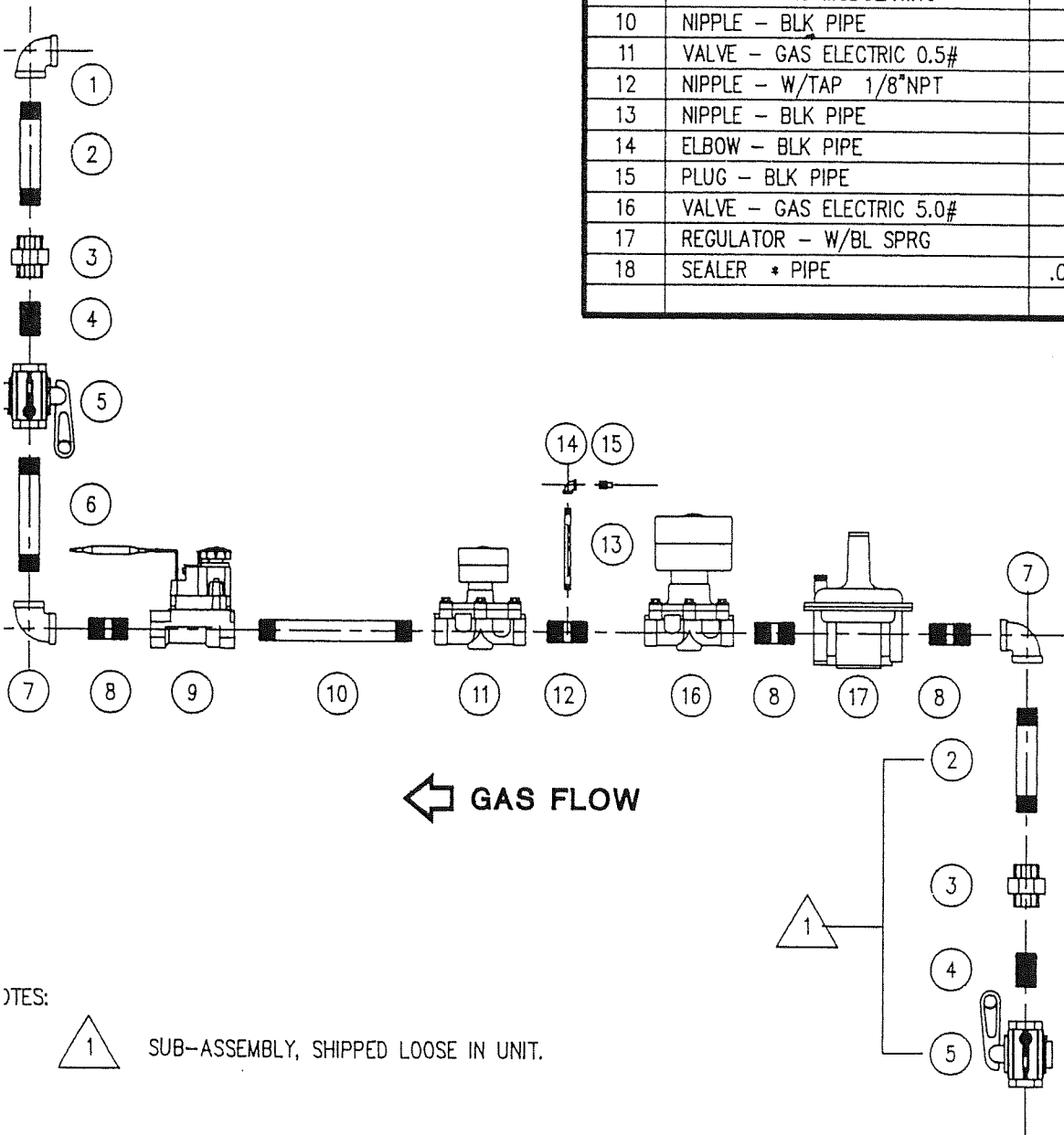

NOTES:



SUB-ASSEMBLY, SHIPPED LOOSE IN UNIT.

CH110/115AGA  
 ED, EDR, EDS PIPING SCHEMATIC  
 (UNDER 400 MBH)

NO.	ITEM	QTY.
1	ELBOW - BLK PIPE	2
2	NIPPLE - BLK PIPE	1
3	UNION - BLK PIPE	1
4	NIPPLE - BLK PIPE	1
5	VALVE - GAS HSOV	1
6	NIPPLE - BLK PIPE	1
7	VALVE - GAS MODULATING	1
8	NIPPLE - BLK PIPE	1
9	VALVE - GAS MODULATING	1
10	NIPPLE - BLK PIPE	1
11	VALVE - COMB. REG & SOV (MOD.)	1
12	NIPPLE - BLK PIPE	1
13	ELBOW - BLK PIPE	1
14	NIPPLE - BLK PIPE	1
15	UNION - BLK PIPE	1
16	NIPPLE - BLK PIPE	1
17	VALVE - GAS HSOV	1
18	SEALER * PIPE	.042

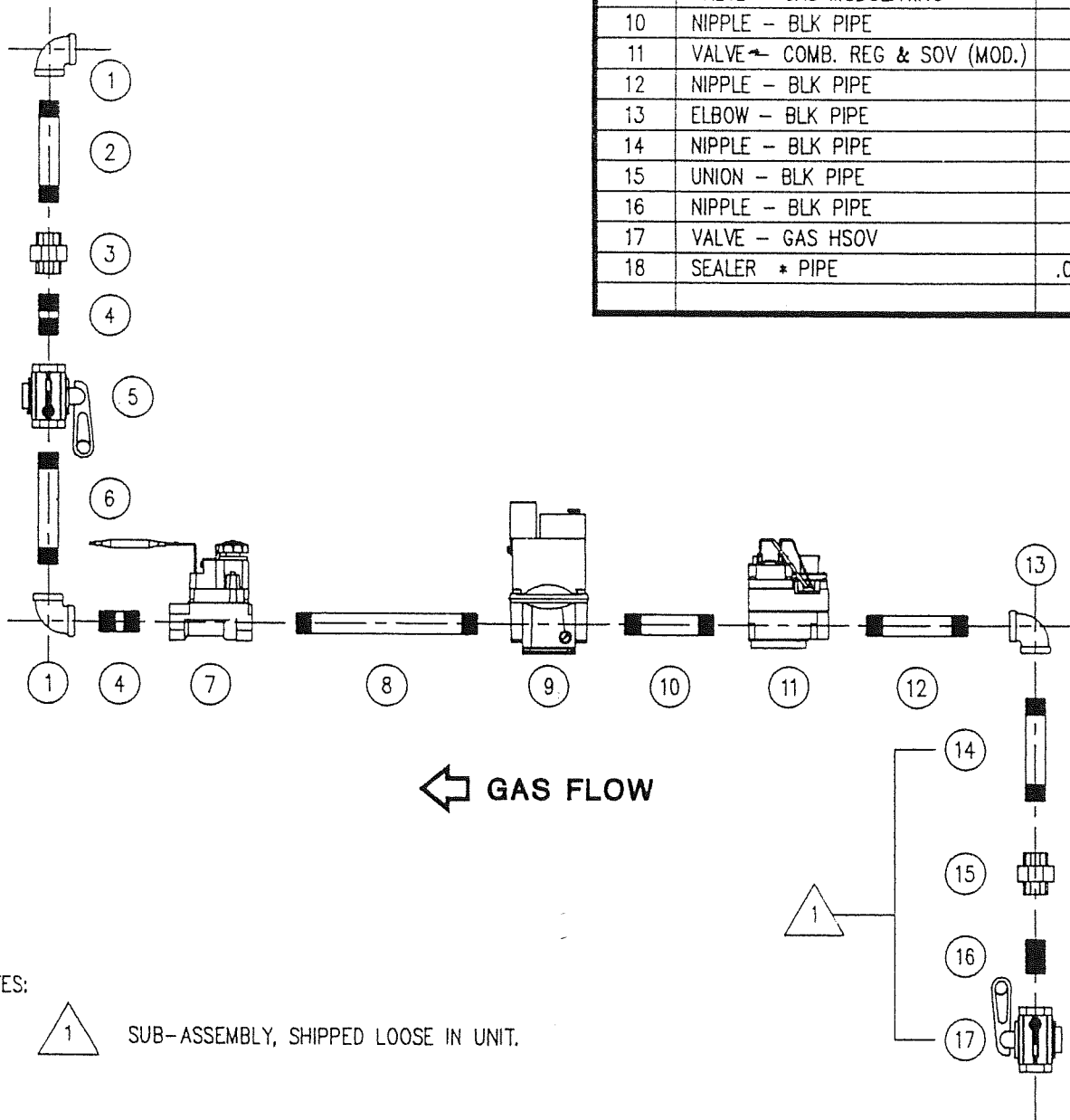

NOTES:

 SUB-ASSEMBLY, SHIPPED LOOSE IN UNIT.

CH110/115AGA  
 ED, EDR, EDS PIPING SCHEMATIC  
 (OVER 400 MBH)

NO.	ITEM	QTY.
1	ELBOW - BLK PIPE (REDUCING)	1
2	NIPPLE - BLK PIPE	2
3	VALVE - GAS HSOV	2
4	NIPPLE - BLK PIPE	5
5	UNION - BLK PIPE	1
6	VALVE - GAS MODULATING	1
7	ELBOW - BLK PIPE	2
8	VALVE - GAS MODULATING	1
9	NIPPLE - BLK PIPE	1
10	VALVE - GAS ELECTRIC 0.5#	1
11	NIPPLE - W/TAP 1/8"NPT	1
12	NIPPLE - BLK PIPE	1
13	ELBOW - BLK PIPE	1
14	PLUG - BLK PIPE	1
15	VALVE - GAS ELECTRIC 5.0#	1
16	REGULATOR - W/BL SPRG	1
17	NIPPLE - BLK PIPE	1
18	NIPPLE - BLK PIPE	1
19	SEALER * PIPE	.042

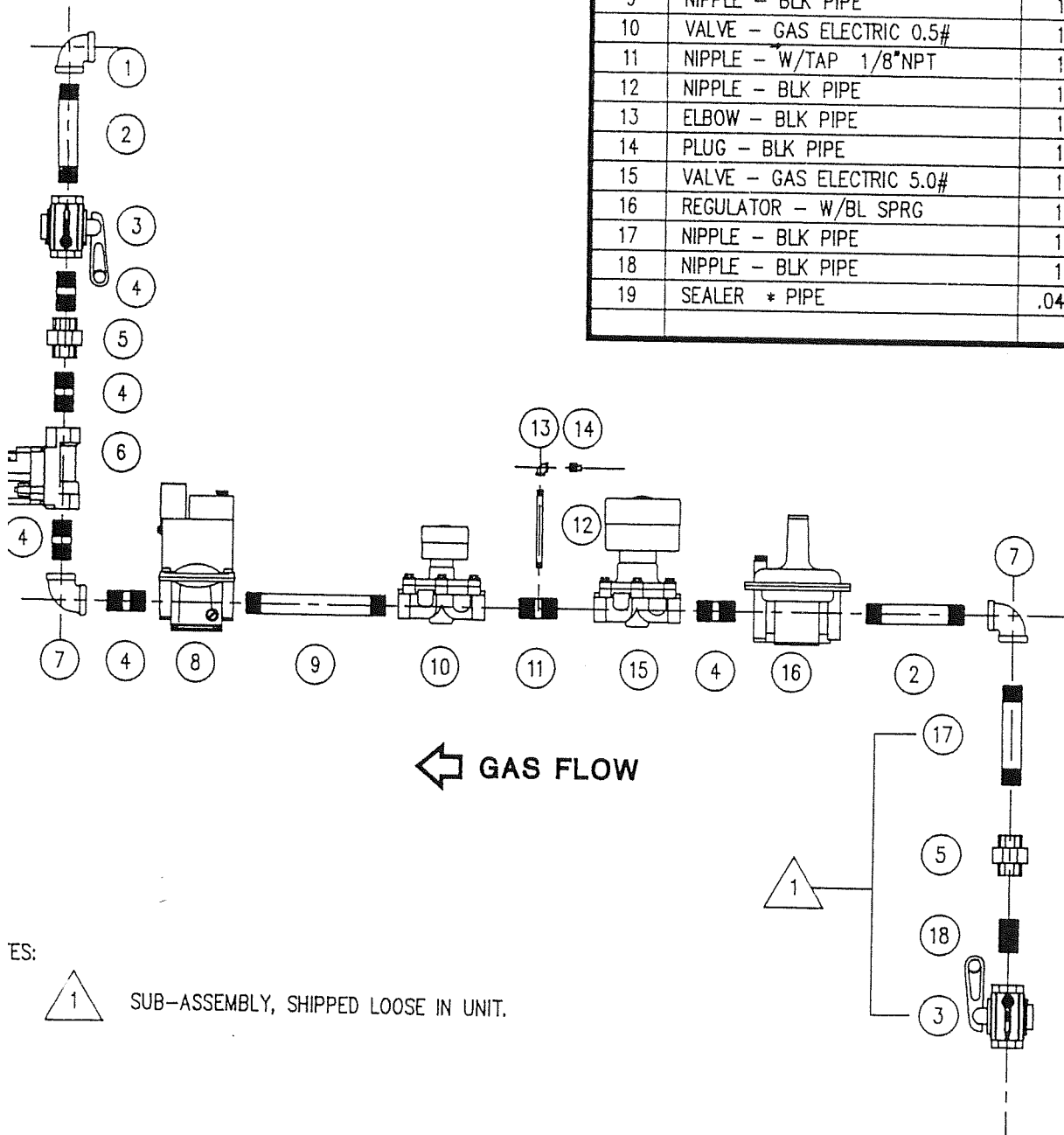



TYPICAL  
DOUBLE BLOCK & VENT GAS TRAIN  
(401MBH AND ABOVE)

NO.	ITEM	QTY.
1	ELBOW - BLK PIPE	3
2	NIPPLE - BLK PIPE	4
3	UNION - BLK PIPE	3
4	NIPPLE - BLK PIPE	5
5	VALVE - GAS HSOV	2
6	TEE - BLK PIPE	3
7	BUSHING - BLK PIPE	2
8	NIPPLE - BLK PIPE	2
9	SWTCH - GAS PRESSURE (HIGH)	1
10	CAP - DUST	1
11	NIPPLE - BLK PIPE	1
12	VALVE - GAS MODULATING	1
13	NIPPLE - BLK PIPE	1
14	VALVE - GAS ELECTRIC 0.5#	1
15	NIPPLE - BLK PIPE	5
16	BUSHING - BLK PIPE	1
17	PLUG - BLK PIPE	1
18	VALVE - GAS VENT	1
19	VENT - CAP	1
20	VALVE - GAS ELECTRIC 5.0#	1
21	VALVE - REGULATOR W/BL SPRG	1
22	SWTCH - GAS PRESSURE (LOW)	1
23	NIPPLE - BLK PIPE	1
24	SEALER * PIPE	.072

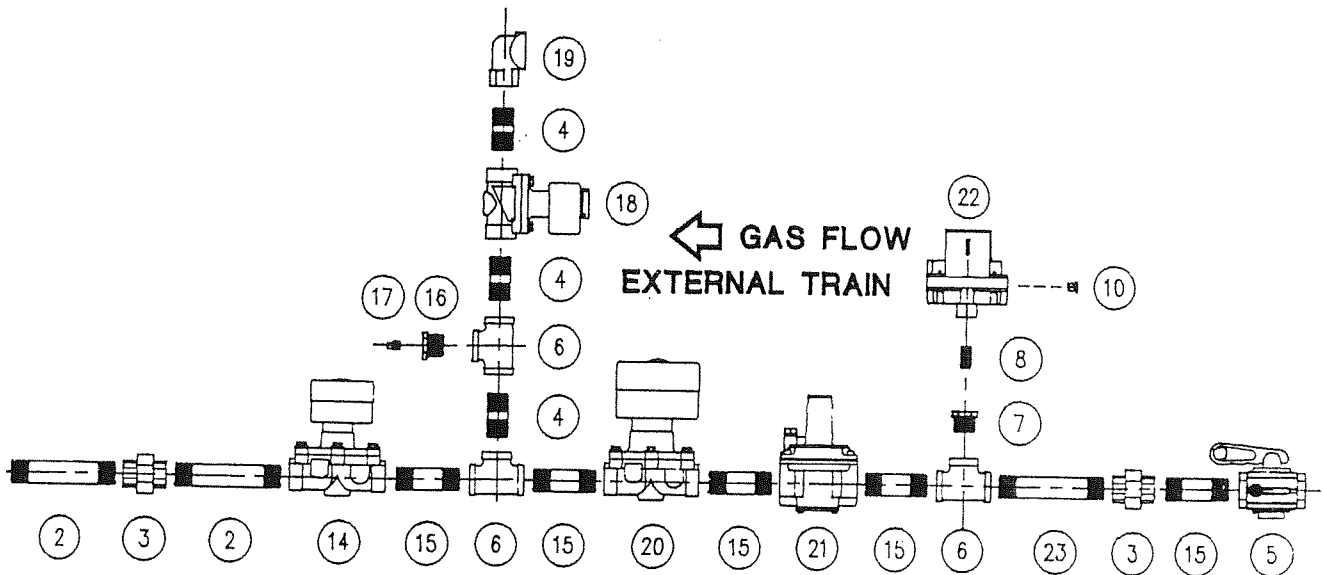
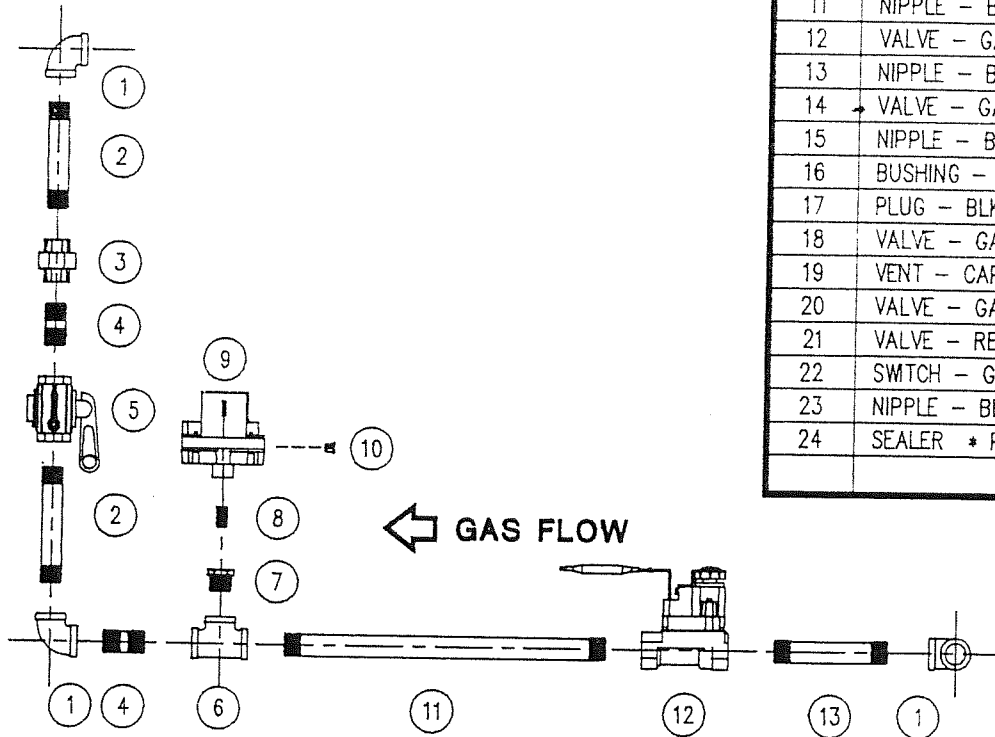

START-UP CHECK SHEET

\* \* \* \* \* NOTE \* \* \* \* \*

Read this entire Start-Up Section (Page 24 and 25)  
before doing the actual start-up.

\* \* \* \* \*

1. Visual Inspection of equipment. (Loose components, belts, plugs, terminal screws.) \_\_\_\_\_
2. Supply voltage. \_\_\_\_\_
3. Check proper rotation of blower. \_\_\_\_\_
4. Check amp draw and adjust motor overload.  
L1 \_\_\_\_\_ L2 \_\_\_\_\_ L3 \_\_\_\_\_ Overload Setting \_\_\_\_\_.
5. Adjust gas supply pressure to comply with nameplate requirements as follows:
  - A. Nameplate Manifold Differential Pressure \_\_\_\_\_
  - B. Manifold Static (Blower On Only) + or - \_\_\_\_\_  
If negative, subtract from nameplate  
If positive, add to nameplate
  - C. Calculated Manifold Pressure = \_\_\_\_\_
6. Leak test complete gas train with burner "on". \_\_\_\_\_
7. Secure unit. \_\_\_\_\_
8. Set thermostats and time clock (if applicable). \_\_\_\_\_

## START-UP PROCEDURES

\* \* \* \* \* **WARNING** \* \* \* \* \*

Read the following instructions carefully. Any unauthorized modification to, or deviation from these instructions may void warranty.

\* \* \* \* \*

### STEP 1

Review wiring diagram and operating sequence. Note special controls and interlocks.

### STEP 4

If voltage is correct and AMP readings are high, excessive blower RPM is indicated. Open motor pulley in 1/2 turn increments until AMP readings are equal to or less than shown on nameplate. Note: AMP readings on three-phase should be the average of the three leads.

### STEP 5      ADJUSTING BURNER MANIFOLD PRESSURE

- a. Turn off power to heater. Set all temperature controls to highest setting during start-up. Units having Entering Air Thermostat (EAT) option require moving wire from right terminal on the stat to left terminal.
- b. Connect manometer to 1/8" tap on manual shutoff valve just prior to the burner. Turn power on and start the blower only and record burner static. The burner static may be positive or negative. If a negative static reading was obtained, subtract that reading from the nameplate manifold pressure to obtain calculated manifold pressure setting. If the burner static was positive, add this to nameplate manifold pressure to obtain adjusted manifold pressure setting.

### STEP 7      SECURE UNIT

Turn disconnect switch to "OFF" position.  
Replace all thermostat wires to their original terminals.  
Return service switches to the remote position.  
Return Technical Manual and Wiring Diagram to manual holder.  
Replace and fasten all covers and panels.

Perform visual inspection of all wiring and gas valve plugs to be sure they have been properly replaced. Turn electrical disconnect switch to "ON" position.

## MD CONTROL OPTION SUMMARY

### General

This system utilizes a mechanical proportioning valve with a discharge-mounted bulb to maintain a constant discharge temperature. The bulb is located in the discharge airstream. The MD valve has an adjustment knob graduated from 1 - 9.

### For Space Heating Application

The MD valve should be in #9 position. For space heating it is desirable to cycle the unit which requires an optional Operating Thermostat. The "OT" (Operating Thermostat) must be connected across Terminals Z1 and Z2. (Terminals located in RCS.)

### For Constant Make-Up Air Application

The MD valve should be set to maintain a discharge temperature approximately 10°F warmer than the desired space temperature. For example -- in a building designed to have a space temperature of 65°F, the MD valve should be set to maintain approximately a 75°F discharge temperature (a setting of about #4 on the dial). An optional Entering Air Thermostat (EAT) should be installed to obtain maximum energy efficiency and prevent overheating during mild weather.

## EDR CONTROL OPTION SUMMARY

### General

This system consists of a Modulating Gas Valve (MV), a MD valve, a discharge thermostat and a remote manual controller (potentiometer). The MD valve is preset at factory and must remain at #9 setting. The Discharge Thermostat mounted in the unit will maintain a minimum discharge temperature. The remote manual controller (potentiometer) will allow the operator to raise the discharge temperature from the Remote Control Station. EDR controls will not cycle the unit "ON" and "OFF".

## EDS CONTROL OPTION SUMMARY

### General

An EDS system consists of a Modulating Gas Valve (MV), a MD valve, a Discharge Thermostat (DT), and a Space Thermostat (ST). The MD valve is preset at factory and must remain on #9 setting. The discharge and space thermostats are connected in parallel. The discharge thermostat mounted in the unit will maintain a constant temperature until the space thermostat senses an uncomfortable condition. The space thermostat then overrides the discharge thermostat and raises the temperature to warm the conditioned area. When the desired temperature is reached, the discharge thermostat regains control. EDS controls will not cycle the unit "ON" and "OFF".

### For Constant Make-Up Air Application

The discharge thermostat should be set at 10°F higher than the desired space temperature. The space thermostat should be set at the desired space temperature. An optional Entering Air Thermostat (EAT) should be installed to obtain maximum energy efficiency and prevent overheating during mild weather.

### For Combination Make-Up Air and Space Heating Applications

The discharge thermostat should be set 10°F higher than the desired space temperature. Set the space thermostat at the desired space temperature. An exhaust fan interlock is necessary to satisfy makeup air requirements. To satisfy space heating when makeup air is not required, you must incorporate the use of an Operating Thermostat to cycle the unit "ON" and "OFF".

## OPERATOR INSTRUCTIONS: REMOTE CONTROL STATION

### I. SUMMER/VENT OPERATION

- a. Place mode switch in the "SUMMER VENT" position. Blower will run until this switch is manually placed in the "OFF" position. Note: Units having Motorized Discharge Damper (MDD) installed will not start until the MDD is completely opened.

### II. WINTER/HEAT OPERATION

- a. Place mode switch in the "WINTER HEAT" position.
- b. Operation of the unit (both blower and heater) is now controlled by the Operating Thermostat "OT" or the closure provided at Terminals Z1 and Z2 by other operating devices.

### III. RESET

In the event combustion failure should occur and the Flame Safeguard Relay does not establish reignition within 30 seconds, the Warning indicator light at the Remote Control Station will come on only if inlet air temperature is below 45°F. Operation of the unit will be interrupted until unit is turned off and back on.

## REMOTE CONTROL STATION (RCS)

The RCS contains a vent-off-heat switch, an amber reset lamp, a green blower lamp and a red heat on lamp in Diagram A.

In addition to the above, the temperature setback system also includes a time clock, operating thermostat and a night override timer as in Diagram B.

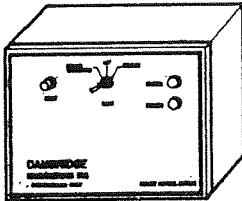

Diagram A

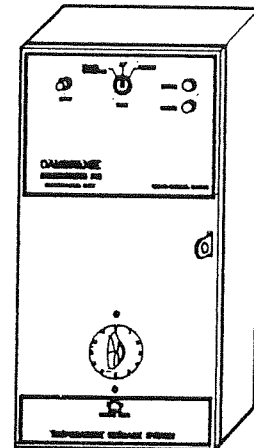

Diagram B

## TEMPERATURE SETBACK SYSTEM (TSS)

The temperature setback (TSS) control will automatically reduce space temperatures during non-occupied hours of nights or weekends. Front panel components consist of a reset alarm light, mode selection switch, blower and heater indicator lights, and an override timer.

a. **Reset Alarm**

The Reset Alarm indicator light is activated when a loss of combustion has occurred while the controls are calling for heat and only if the inlet air temperature is below 45°F. The unit must be turned off momentarily. Turn on to reactivate system.

b. **Mode Switch**

The mode switch is a three position switch that selects "SUMMER VENTILATION" mode, "OFF", or "WINTER HEAT" mode. Selecting "SUMMER VENTILATION" mode will enable the blower only. The blower will run continuously until the mode switch is turned to the "OFF" position. With the mode switch in the "WINTER HEAT" position, both the blower and burner will be cycled by the setting of the OT or Night Setback Thermostat.

c. **Lights**

The "GREEN" blower light will be illuminated when the blower is "ON". The "RED" heat light will be illuminated when the burner is "ON". The "AMBER" Warning light will be illuminated when unit is in "Lock-out".

d. **TSS Override Timer Switch**

Turn override timer in the clockwise direction to the desired length of time override is required. When in the override position, the temperature set point of the OT will be maintained.

## OPERATION OF THE TSS TIMER

### KEY FUNCTIONS FOR TM-2 TIMER

- DAY For setting day only - one press and release will advance one day.
- HOUR For setting hour only (will not affect day at midnight), one press and release will advance one hour. By holding in, hours will advance rapidly.
- MINUTE For setting minutes only (will not affect hour), one press and release will advance one minute. By holding in, Minutes will advance rapidly.
- CHANGE DO NOT USE.
- CLK/SET Used to change from CLOCK display to PROGRAM set/change.
- ON/OFF Used to change display to ON or OFF times for programming. Also, MUST be used as an ENTER key for ON/OFF times displayed to memory.
- 1-6 DO NOT USE.
- SEP/AUTO Used to change from "different daily programming" (SEP) to "all days alike" (AUTO).

The TM-2 Seven Day Timer incorporates two modes of operation. For our operation, only one mode will be used. The mode switch is located on the rear of the front case.

The mode switch has an off position which disconnects ALL power from the TM-2, including battery power. The TM-2 is shipped with this switch in the off position and must be switched to single for operation. This switch is also used to clear memory by placing switch to off and then to single mode. Always leave switch in single mode.

\* \* \* \* \* \*CAUTION\* \* \* \* \*

Do not switch to off after programming. Memory will be lost.

\* \*

### BATTERY BACK-UP

Nicad batteries are automatically charged when power is applied to the TM-2. When fully charged, they will retain the program memory for up to two weeks.

Batteries are built in and cannot be replaced.

# OPERATION OF THE TSS TIMER

## PROGRAMMING

### TO SET ALL DAYS ALIKE

1. Press CLK/SET button.

Display will look like this:  
Notice ON is displayed.

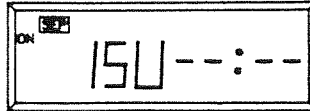

2. Set HOUR and MINUTE buttons until desired ON time is displayed.
3. Press ON/OFF button to enter in memory. Notice OFF is displayed.
4. Set HOUR and MINUTE buttons until desired OFF time is displayed.
5. Press ON/OFF button to enter into memory.

Display will look like this:

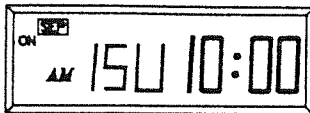

6. Press SEP/AUTO button. AUTO will appear to left of SUnday.
7. Programming is now complete. Press CLK/SET button to return to correct day and time. Refer to note below and proceed to set today's correct time.

### TO SET DAY ON/OFF TIMES DIFFERENTLY

1. Fill out on-off times, by day, on the enclosed chart.
2. Press CLK/SET button.

Display will look like this:

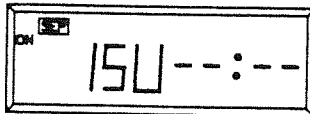

3. Set Sunday's ON hours AM or PM and minutes.
4. Press ON/OFF button to enter into memory. Notice OFF is now displayed.
5. Set Sunday's OFF hours AM or PM and minutes.
6. Press ON/OFF button to enter into memory. Notice ON is now displayed.
7. Press day button. - MO will be displayed.
8. Enter hours and minutes. Repeat this procedure (Items 3 thru 6) for each day until all 7 days are programmed.
9. Programming is now complete.

\*\*\*\*\* NOTE \*\*\*\*\*

For initial operation, if unit is to be ON set Day and Time to 1 minute before ON function is to occur. Wait until clock has operated ON function, then set to correct day and time. If unit is to be OFF, set day and time to 1 minute before OFF function is to occur. Wait until clock has operated OFF function and then set correct day and time as follows.

\*\*\*\*\*



# OPERATION OF THE TSS TIMER

## PROGRAMMING (Cont'd)

### SET TODAY'S CORRECT TIME

1. Press CLK/SET button until CLK appears in lower left corner of display.
2. Press DAY button until today's day appears.
3. Press HOUR button until correct hours AM or PM appears.
4. Press MIN. button until correct minute appears.
5. Time is now set.

Display will look like this:

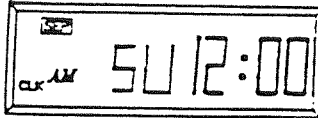

### POINTS TO REMEMBER

1. To clear ALL programs, turn mode switch off then to single position.
2. If a mistake is made, reprogram over existing program.
3. ON/OFF button must be used to enter every on or off program.
4. To review the existing program, push CLK/SET button and then day button to advance to the day being reviewed.
5. Always return display to read today's time.

## TSS PROGRAM CHART

DAY	PROGRAM	TIME
SU	ON	
	OFF	
MO	ON	
	OFF	
TU	ON	
	OFF	
WE	ON	
	OFF	
TH	ON	
	OFF	
FR	ON	
	OFF	
SA	ON	
	OFF	

DAY	PROGRAM	TIME
SU	ON	
	OFF	
MO	ON	
	OFF	
TU	ON	
	OFF	
WE	ON	
	OFF	
TH	ON	
	OFF	
FR	ON	
	OFF	
SA	ON	
	OFF	

DAY	PROGRAM	TIME
SU	ON	
	OFF	
MO	ON	
	OFF	
TU	ON	
	OFF	
WE	ON	
	OFF	
TH	ON	
	OFF	
FR	ON	
	OFF	
SA	ON	
	OFF	

## OPERATION SEQUENCE: (SINGLE SPEED MOTOR)

### POWER ON

- a. Control transformer energized.
- b. Operator must select "SUMMER VENT" or "WINTER HEAT" mode.

### SUMMER VENT MODE

- a. Mode switch to "SUMMER VENT" position.
- b. Damper opens (optional).
- c. Blower motor starts.
- d. Unit continues to run until manually turned off.

### WINTER HEAT MODE

- a. Mode switch "WINTER HEAT" position.
- b. Power to operating stat or interlock (nothing occurs until this control calls for heat).
- c. Damper opens (optional).
- d. Blower motor starts.
- e. Air flow switch closes.
- f. Entering air stat (optional) closes.
- g. Igniter warm up timing (pre-purge).
- h. Gas valve opens.
- i. Burner lights.
- j. Ignition stopped.
- k. Unit runs until operating stat interlock opens (unit shuts off).
- l. Steps b. thru k. repeat themselves automatically as necessary.

CONTROL SEQUENCE: (SINGLE SPEED MOTOR)

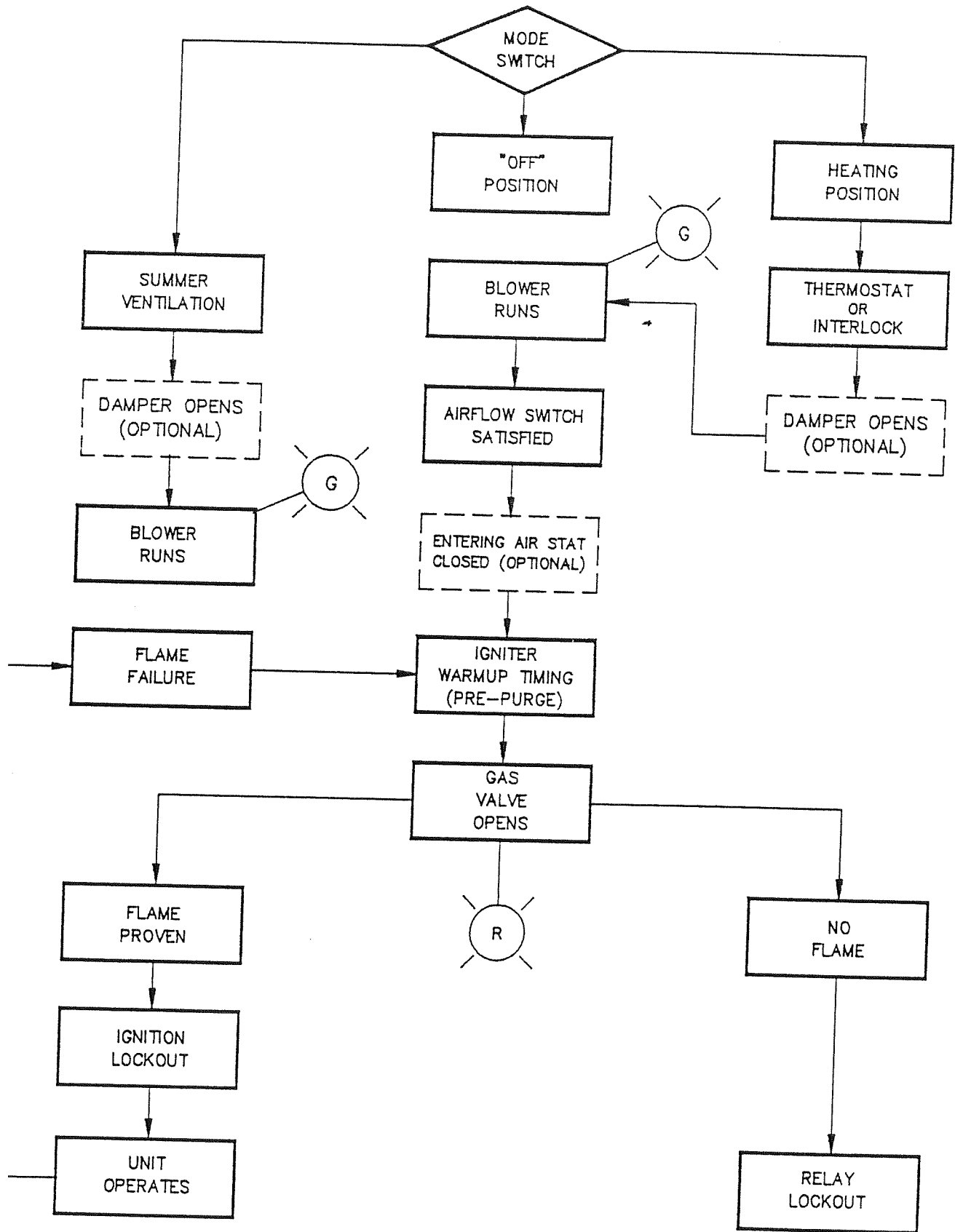

## OPERATION SEQUENCE: (TWO SPEED MOTOR)

### POWER ON

- a. Control transformer energized.
- b. Operator selects high or low motor speed.

### SUMMER VENT MODE

- a. Select desired motor speed (high or low).
- b. Mode switch to "SUMMER VENT" position.
- c. Damper opens (optional).
- d. Blower motor starts.
- e. Unit continues to run until manually turned off.

### WINTER HEAT MODE

- a. Select desired motor speed (high or low).
- b. Mode switch "WINTER HEAT" position.
- c. Power to operating stat or interlock (nothing occurs until this control calls for heat).
- d. Damper opens (optional).
- e. Blower motor starts.
- f. Air flow switch closes.
- g. Entering air stat (optional) closes.
- h. Igniter warm up timing (pre-purge).
- i. Gas valve opens.
- j. Burner lights.
- k. Ignition stopped.
- l. Unit runs until operating stat or interlock opens (unit shuts off).
- m. Steps b. thru l. repeat themselves automatically as necessary.

CONTROL SEQUENCE: (TWO SPEED MOTOR)

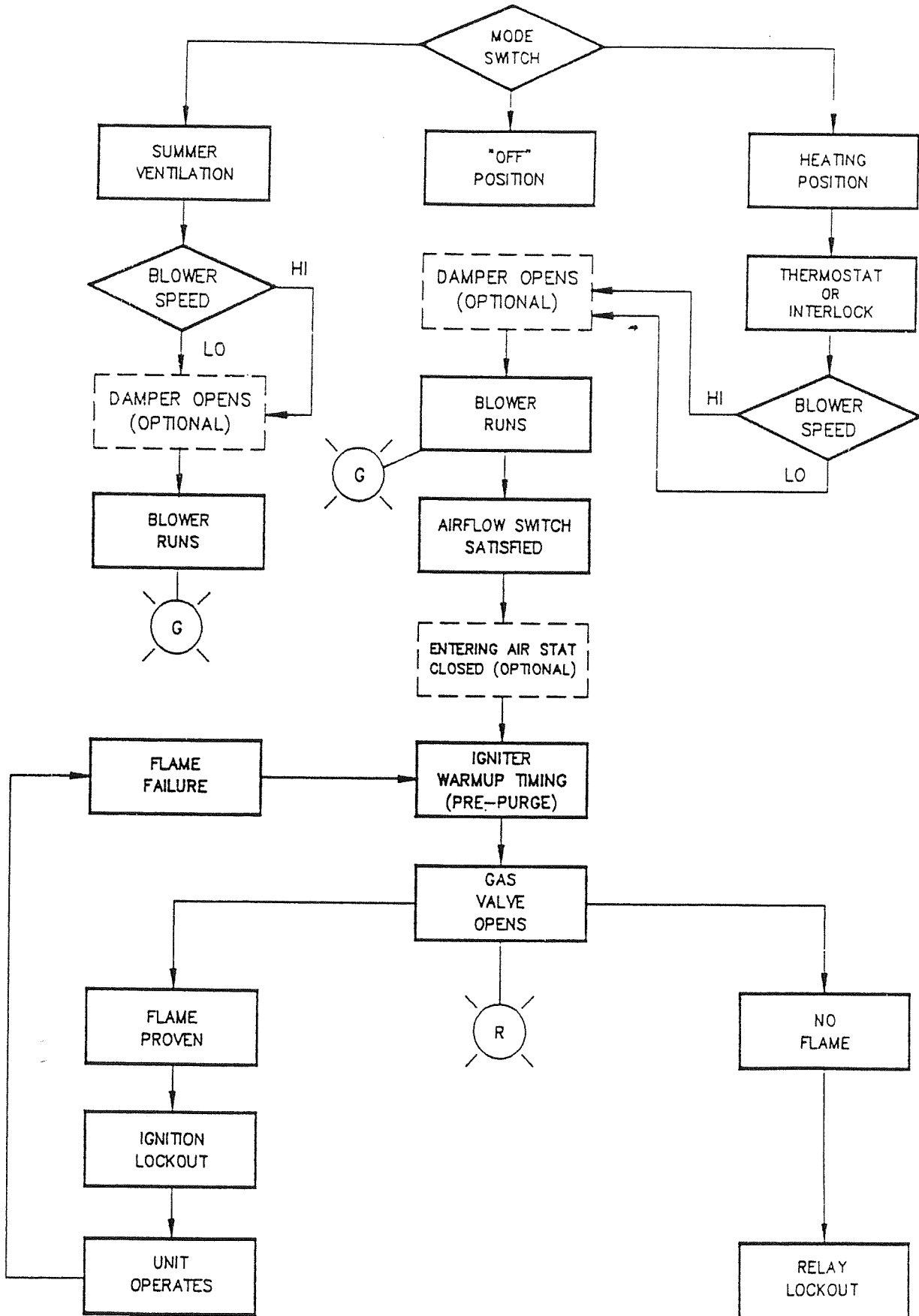

## INDIVIDUAL COMPONENT FUNCTIONS

### TRANSFORMER

- Reduces input voltage to low voltage (110V or 24V) for control circuit.

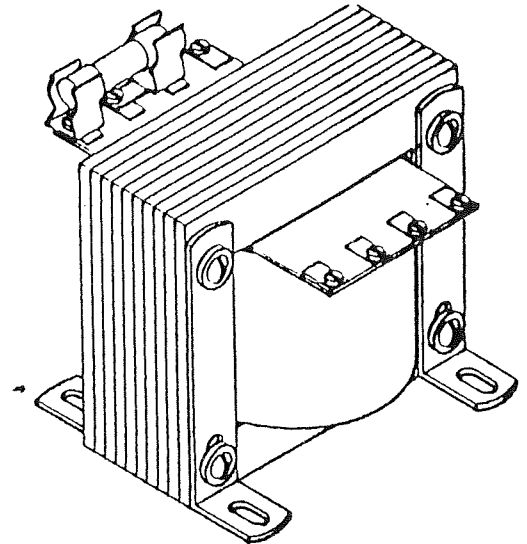

### FLAME ROD

- Senses flame and signals flame safeguard relay to stop ignition. Also senses loss of flame.

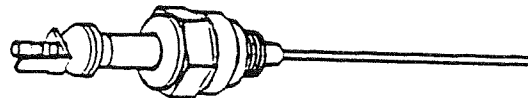

### HIGH LOW GAS PRESSURE SWITCH

- A HLGP is installed on all IRI and FM gas trains. The HLGP is a safety device to lock out the unit electrically should large gas pressure fluctuations occur. The high pressure switch should be set at 4" above manifold gas pressure and the low pressure switch should be set at 2" water column. Adjustment screws can be accessed by removing the two screws securing the top plate. The low pressure switch will have to be reset whenever gas supply has been interrupted.

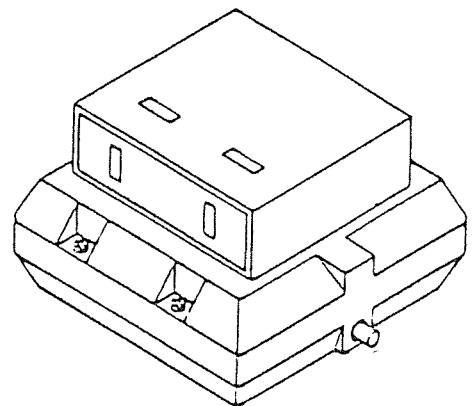

## INDIVIDUAL COMPONENT FUNCTIONS

HIGH TEMPERATURE LIMIT - The high limit opens when discharge air temperature exceeds 180°F. Must be manually reset.

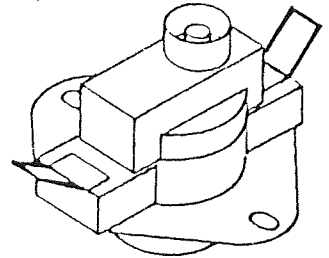

AIR FLOW SWITCH - Closes when pressure drop across burner reaches the setpoint of the airflow switch. Will not allow flame safeguard relay to function unless proper airflow is sensed.

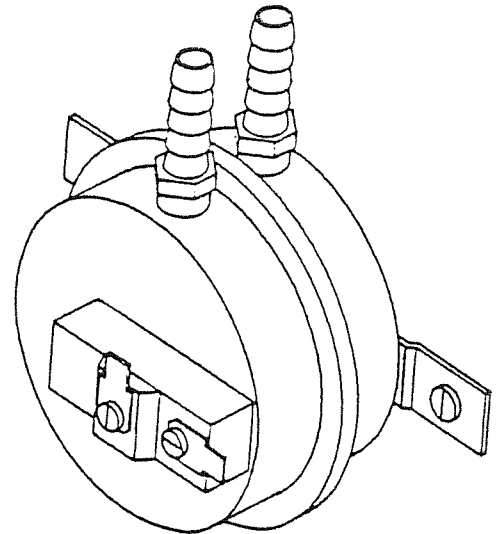

MOTOR CONTACTOR AND OVERLOAD -

Protects the motor from high current draw. Must be manually reset.

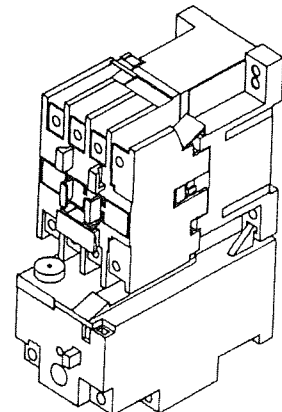

## INDIVIDUAL COMPONENT FUNCTIONS

**PRESSURE REGULATOR**

- Adjusted to maintain correct burner manifold pressure.

MANIFOLD PRESSURE  
ADJUSTMENT SCREW  
(under cover)

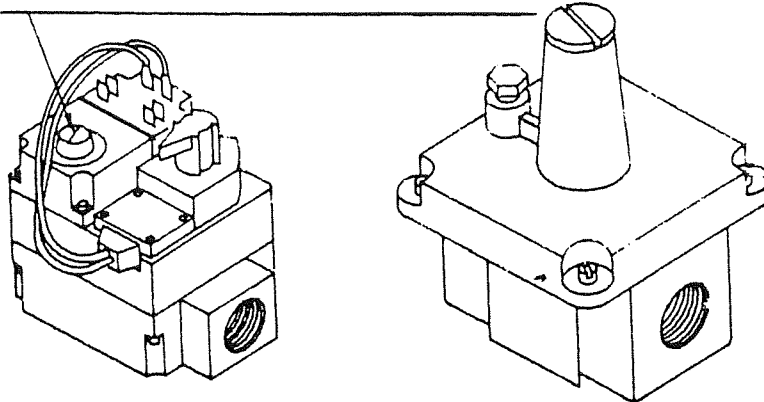

**MD TEMPERATURE  
CONTROL VALVE**

- Mechanical proportioning valve used to maintain constant discharge temperature. Sensing bulb is mounted in discharge airstream.

For space heating applications typically set on #9 setting.  
For make-up air (without EDR or EDS controls) typically set on #4 setting. For make-up air with EDR or EDS controls - always set on #9 setting.

<u>SETTING</u>	<u>DISCHARGE TEMPERATURE (°F)</u>
#1	41
#2	53
#3	65
#4	77
#5	89
#6	101
#7	114
#8	127
#9	140

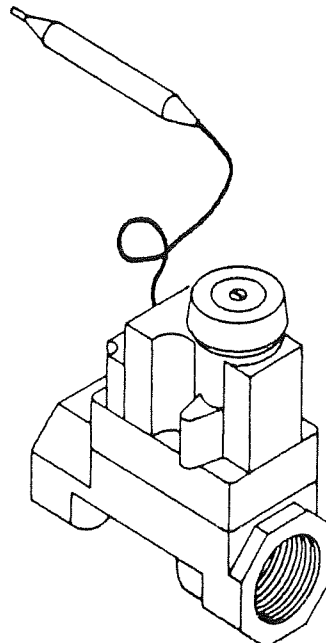



## INDIVIDUAL COMPONENT FUNCTIONS

### MV TEMPERATURE CONTROL VALVE

- An electronically controlled modulating gas valve. The electronic controls consist of a discharge sensor monitoring the discharge air temperature, a reostat type heat adjuster or a space thermostat, and a D.C. Power Supply.

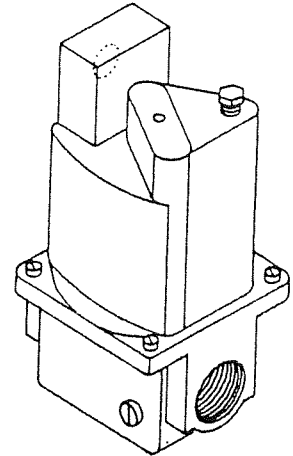

### FLAME SAFEGUARD RELAY

- Applies control voltage to gas safety shutoff valve. Supplies ignition voltage to igniter. Senses absence/presence of flame through flame rod. Should loss of flame occur, FSR will attempt re-ignition. Safety reset will open if flame is not detected within 7 seconds.

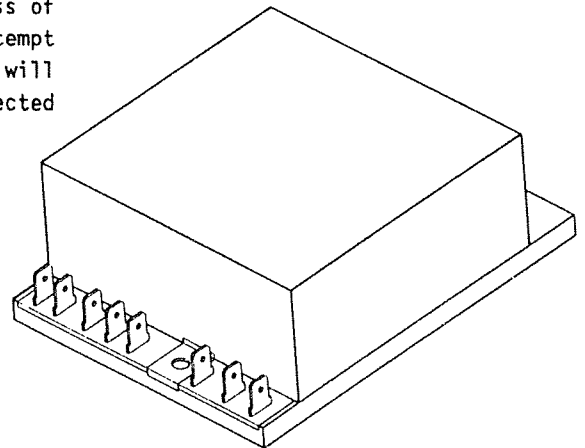

### IGNITER

- Provides hot surface to ignite gas in burner.

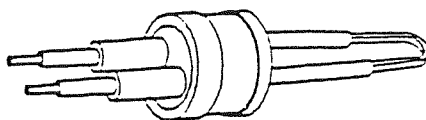

## DAMPER MOTOR WIRING

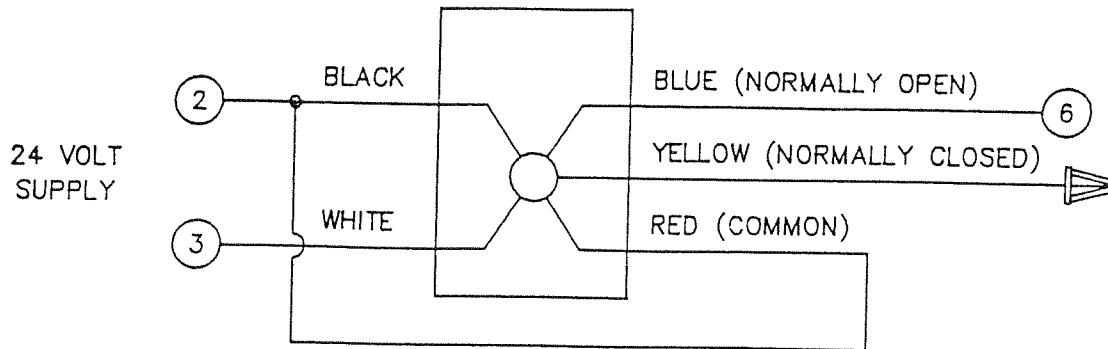

## AUXILLIARY SWITCH

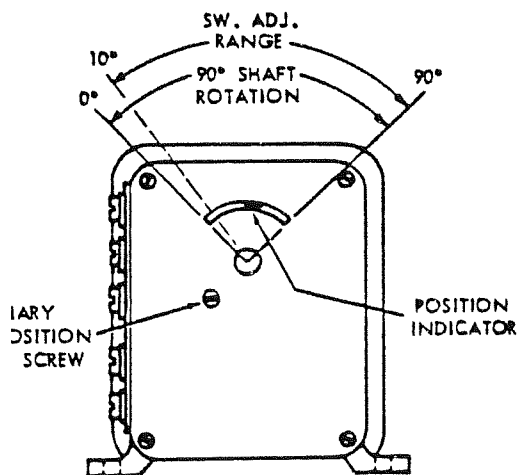

The internal SPDT auxiliary switch has been factory adjusted to operate when the damper is fully open. The switch will close the R-B circuits (N.O. contacts) during the power stroke (shaft rotating counterclockwise, viewed from flange end).

To readjust switch proceed as follows:

- Loosen locking screw.
- Adjust position indicator to approximate midpoint of slot and tighten locking screw.
- Apply power to motor.
- Note system function when switch operates.
- If damper motor has not rotated far enough when switch operates, move indicator clockwise.
- If damper motor has rotated too far, move indicator counterclockwise.
- Repeat power stroke and note system function.
- Re-adjust as necessary.
- Tighten locking screw.

## TROUBLESHOOTING GUIDE

<u>PROBLEM</u>	<u>POSSIBLE CAUSE</u>	<u>CORRECTIVE ACTION</u>
<u>NO BLOWER</u>	1. Control Transformer. A) No input voltage. B) Blown control fuse. C) Defective transformer.	A) Check disconnect and supply fusing. B) Replace control fuse. C) Replace transformer.
	2. Blower Switch. A) Switch in improper position. B) Defective switch.	A) Place in proper mode. B) Replace switch.
	3. Low Temperature Cutout. A) Low temperature cutout Timed Out - (If outside temperature is below 45°.	A) Turn unit off momentarily and turn unit on.
	4. Damper Switch A) Switch not made.	A) Adjust end switch.
	5. Motor Protection. A) Overload relay tripped. B) Overload relay defective.	A) Check motor amps/overload setting. B) Replace.
	6. Motor Contactor. A) Defective contactor. B) No switching action.	A) Replace contactor. B) Replace contactor.
	7. Motor. A) Improper wiring. B) Defective motor. C) No input voltage.	A) Correct wiring. B) Replace motor. C) Check fusing.
	8. Belts and Drives. A) Broken or loose belt. B) Broken or slipping pulley.	A) Replace or tighten belt. B) Tighten or replace pulley.
	9. Blower Damage. A) Bad or locked bearings. B) Check for physical damage.	A) Replace bearings. B) Replace or repair blower.
	10. Flame Safeguard Relay Safety Reset. A) Reset indicator light on.	A) Turn unit off, wait momentarily and turn unit on.
	11. Control Relays A) Control Relay CR-1 B) Not picking	A) Check Relay voltage. B) Check contact closures.

## TROUBLESHOOTING GUIDE

<u>PROBLEM</u>	<u>POSSIBLE CAUSE</u>	<u>CORRECTIVE ACTION</u>
BLOWER RUNS; NO HEAT; DOESN'T LOCKOUT	1. Flame Safeguard Relay. A) No input voltage.	A) Check wiring.
BLOWER RUNS; NO HEAT; UNIT RESETS	1. Igniter. A) No current. B) No voltage.	A) Open igniter. B) Check circuits.
	2. Gas Valve. A) No input voltage. B) Faulty solenoid. C) Locked up gas valve.	A) Check 110 volt circuits. B) Replace gas valve. C) Inlet pressure too high. May require high pressure regulator.
	3. Regulator. A) Clogged vent orifice. B) No supply pressure. C) Defective regulator. D) Improper manifold pressure.	A) Clean or replace orifice. B) Check all gas cocks and piping. C) Replace regulator. D) Adjust regulator. (See Page 19-20)
	4. Air Flow Switch. A) Clogged pitot tube or tubing. B) No switching action.	A) Clean or replace tube and tubing. B) Replace switch.
	5. Low Air Flow. A) Blocked intake or discharge. B) Blower rotation.	A) Find and remove obstruction. B) Reverse motor direction.
	6. Hi-Temp Limit. A) Hi Limit tripping. B) Open contacts in limit.	A) Push reset button. B) Replace limit.

## TROUBLESHOOTING GUIDE

<u>PROBLEM</u>	<u>POSSIBLE CAUSE</u>	<u>CORRECTIVE ACTION</u>
BLOWER RUNS; UNIT HEATS; UNIT RESETS	1. Flame Rod. A) Faulty flame rod or lead.  B) Flame rod not located in flame.	A) Replace flame rod or lead. B) Adjust burner manifold pressure.
	2. Flame Safeguard Relay. A) Faulty relay. B) Improper air flow across burner. C) Loss of flame signal.	A) Replace relay. B) Adjust air flow burner. C) Check all grounds.
BLOWER RUNS; UNIT HEATS; SHORT CYCLE WITHOUT RE- SETTING	1. Air Flow Switch. A) Defective switch. B) Clogged or dirty pitot tube or tubing.	A) Replace switch. B) Clean or replace pitot tube or tubing.
	2. Faulty Safeguard Relay. A) Faulty relay.	A) Replace relay.
BLOWER RUNS; UNIT HEATS; UNIT TRIPS HIGH LIMIT	1. High Limit. A) Defective limit.	A) Replace high limit.
	2. Temperature Controller. A) No modulation; discharge is too hot. B) Improper supply pressure.	A) Adjust or replace controller. B) Adjust regulator.
	3. A) Discharge Damper.	A) Readjust damper.
	4. A) Clogged intake.	A) Remove obstruction.

## TROUBLESHOOTING GUIDE

<u>PROBLEM</u>	<u>POSSIBLE CAUSE</u>	<u>CORRECTIVE ACTION</u>
<b>BLOWER RUNS; UNIT HEATS; INADEQUATE HEAT OUTPUT</b>	1. Regulator Adjustment. A) Wrong size spring. B) Regulator not properly adjusted. C) Clogged vent orifice.	A) Replace spring. B) Adjust regulator. C) Clean or replace vent on regulator.
	2. Temperature Controller Adjustment. A) Control sensor in wrong location. B) Controller setting is too low. C) Defective controller. D) Bad amplifier.	A) Mount sensor in bracket provided. B) Adjust temperature controller. C) Replace controller. D) Check output voltages.
	3. Inadequate Gas Supply. A) Regulator adjustment. B) Improper high pressure regulator. C) Pipe too small. D) Supply pressure too low.	A) Adjust regulator. B) Check flow capacity on regulator; replace as needed. C) Check flow capacity of pipe; replace as needed. D) Call utility company.

## MAINTENANCE INSTRUCTIONS

\* \* \* \* \* WARNING \* \* \* \* \*

Place electrical disconnect switch in "OFF" position when performing the following.

\* \* \* \* \*

1. Motor bearings should be lubricated at one year intervals. Use Shell Dolium R, medium consistency, Polyurea lubricant. Blower bearings are permanently lubricated.
2. Drive belts should be checked for proper adjustment after each season's use. Check for a belt deflection of 3/8" to 1/2" with a 6 to 7 lb. force applied inwardly at the center of the belt span.
3. Blower wheel should be examined periodically for accumulation of dust on the concave side of the blades. These surfaces must be kept clean because dirt accumulation will result in greatly reduced air flows.
4. Annual check should be made of burner and components. Check burner plates for carbon buildup and clean if necessary. Clean flame rod and examine porcelain for cracks. Refer to burner cleaning procedures on next page.
5. Periodically check gas control assembly, internal and external piping for leaks. Relief vents on gas controls should be checked for clogging.
6. An annual check of the air tube for the air flow switch should be made to insure against blockage.

## BURNER CLEANING PROCEDURE

The Cambridge Engineering burner is for the most part self-cleaning. However, if the application is extremely dirty or dusty, it may become necessary to periodically clean the burner. Remove and clean the burner in accordance with the following recommended procedures:

1. Shut off electrical disconnect to unit. Shut off the gas cock that supplies gas to the unit.
2. Loosen unions in the gas train and relocate gas train assembly out of the way for burner removal.
3. Disconnect ignition cable and flame sensor lead from burner and then remove flame rod and igniter.

\* \* \* \* \* CAUTION \* \* \* \* \*

Igniter is made of a silicon carbide material and is extremely fragile. Do not bump, jar, or drop.

\* \* \* \* \*

4. Remove fasteners that secure burner to housing. Burner will be free to slide out with removal of the last fastener.
5. Clean burner by back-flushing, using high pressure air (40-80#). Be sure to take necessary safety precautions (such as wearing eye protection, etc.) before attempting this step. Continue back-flushing until dust particles are completely expelled from burner.
6. Reassemble burner, using above steps in reverse order.



BURNER ISOMETRIC

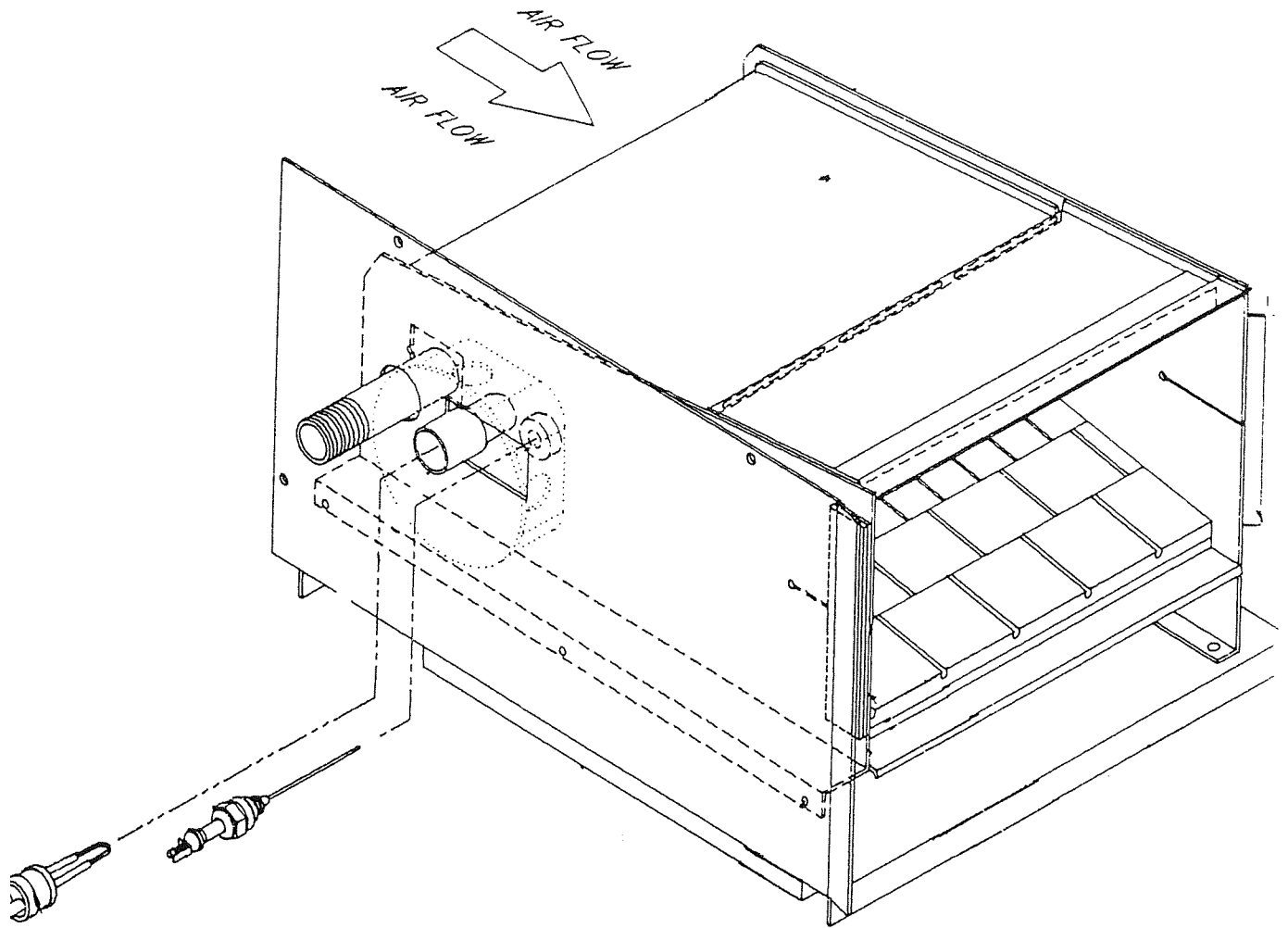

# CH110AGA UNIT ISOMETRIC DRAWING

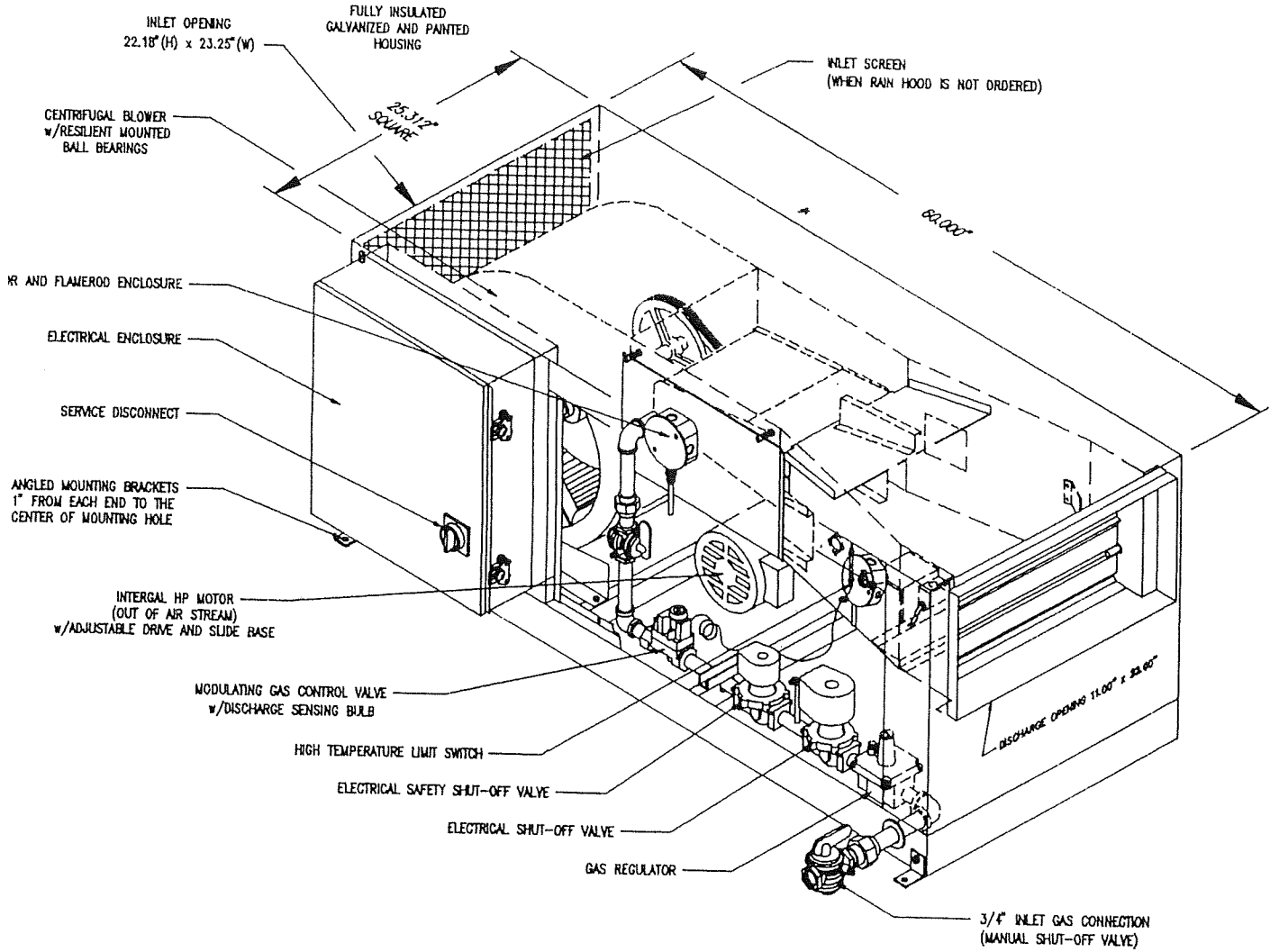

# CH115AGA UNIT ISOMETRIC DRAWING

