

DIRECT GAS FIRED HEATING

TECHNICAL MANUAL

R215G

FOR YOUR SAFETY

THE USE AND STORAGE OF GASOLINE OR OTHER FLAMMABLE VAPORS AND LIQUIDS IN OPEN CONTAINERS IN THE VICINITY OF THIS APPLIANCE IS HAZARDOUS.

FOR YOUR SAFETY

IF YOU SMELL GAS:

1. OPEN WINDOWS.
2. DON'T TOUCH ELECTRICAL SWITCHES.
3. EXTINGUISH ANY OPEN FLAME.
4. IMMEDIATELY CALL YOUR GAS SUPPLIER.

CAMBRIDGE
ENGINEERING INC

R215G

INDEX

| | | |
|--|--------|---------|
| HAZARD SUMMARY | 1 | |
| UNCRATING INSTRUCTIONS | 2 | |
| ACCESSORY OPTIONS | 3 | |
| DIMENSION AND SPECIFICATIONS | 4 | |
| EQUIPMENT INSTALLATION | 5 | THRU 9 |
| ELECTRICAL INSTALLATION | 10, 11 | |
| GAS PIPING INSTALLATION | 12, 13 | |
| START-UP WORK SHEETS | 14, 15 | |
| START-UP PROCEDURES | 16 | THRU 22 |
| REMOTE CONTROL STATION | 23 | |
| CONTROL OPTIONS AND ADJUSTMENTS | 24 | THRU 27 |
| NIGHT SETBACK SYSTEM INSTALLATION INSTRUCTIONS | 28 | THRU 30 |
| NIGHT SETBACK SYSTEM OPERATOR INSTRUCTIONS | 31 | |
| OPERATING SEQUENCE | 32 | |
| COMPONENT FUNCTIONS | 33 | THRU 38 |
| TROUBLESHOOTING | 39 | THRU 42 |
| MAINTENANCE | 43 | |
| BURNER CLEANING PROCEDURE | 44 | |
| WARRANTY | 45 | |

HAZARD SUMMARY

The following safety precautions apply to the installation, operation, and maintenance of the equipment described by this technical manual.

-CAUTION-

Only qualified personnel should attempt installation, service, and repair of this equipment. Use extreme caution and observe safety regulations at all times.

DO NOT RECIRCULATE IN THE FOLLOWING APPLICATIONS:

1. High Hazard Areas:

Grain elevators, ammunition stores, paint spraying or storage, dry cleaning, or any process area using flammable solids, liquids or gases.

2. Fluorinated Hydrocarbons:

Areas where urethane foam is being used, or any area with concentrations of freons, refrigerants or aerosols.

-NOTE-

Direct gas-fired recirculation requires a minimum of 4 CFM of fresh air ventilation per 1000 BTU/Hour of heat input.

-WARNING-

Any unauthorized modifications to this equipment may void warranty.

UNCRATING INSTRUCTIONS

- a. Verify number of items shipped with number of items received.
- b. Remove items from shipping cartons and check for damage.
- c. If damage in transit is found, notify carrier immediately for claim.
- d. Check items received and verify data on nameplates to make sure it agrees with ordering information.
- e. Do not discard any components and accessories or make any unauthorized substitutions.
- f. Familiarize yourself with physical characteristics of unit and accessories.

-CAUTION-

DO NOT remove unit from skid. Utilize skid to prevent damage during mounting.

-NOTE-

Factory service information available;
contact Cambridge Systems Services department
at (314) 532-2233.

ACCESSORIES & OPTIONS

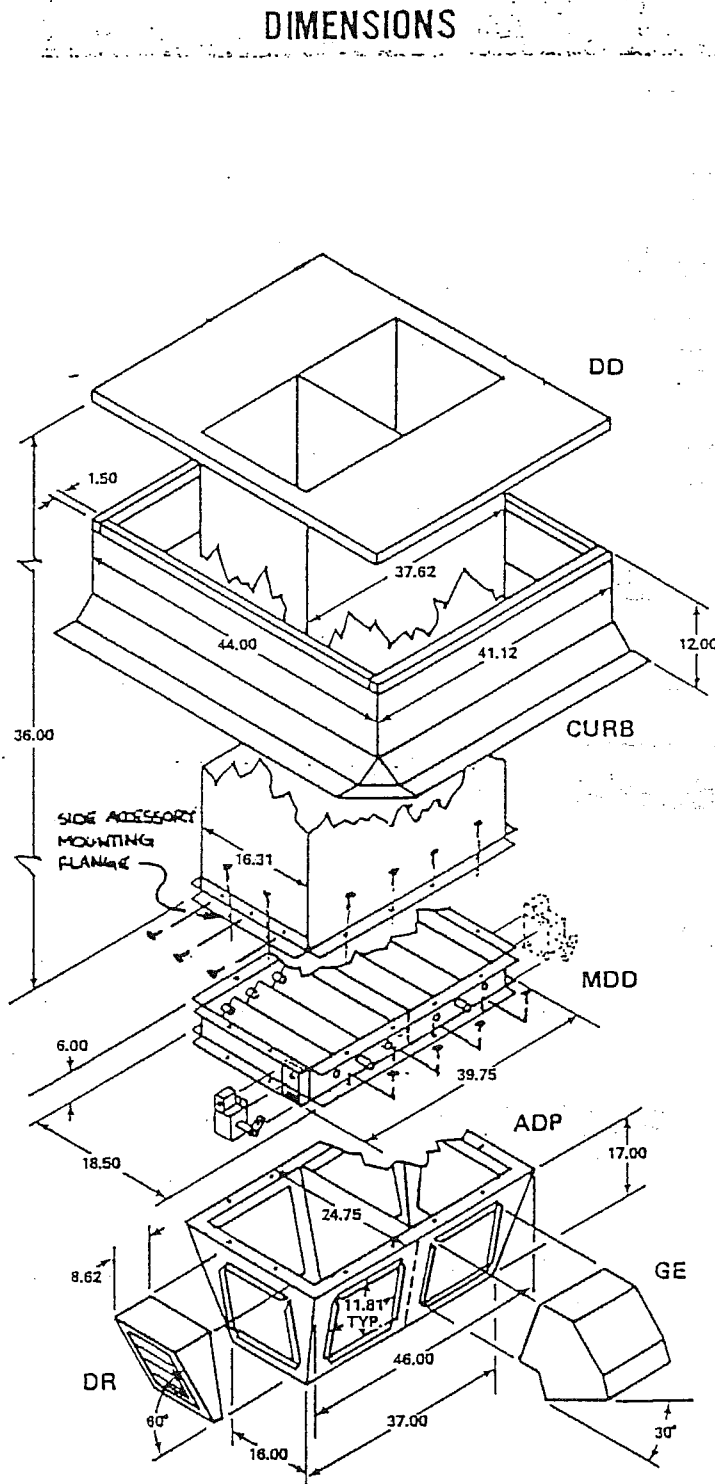

DIMENSIONS TYPE DESCRIPTION

DD DISCHARGE DUCT — Required accessory which provides an interface for the return air dampers, electrical connections, gas piping and temperature control bulbs.

CURB CURB — Insulated roof curb with integral cant and nailing strip.

MDD MOTORIZED DISCHARGE DAMPER for indoor mounting with two (2) position motor and linkage. Constructed of galvanized steel and painted. One actuator for single operation/two actuators for dual operation. Damper motor(s) ships loose for field installation and connection.

ADP AIR DIFFUSER PLENUM — The four way air diffuser plenum gives simple and effective air distribution for most space heating and make-up air applications. The four (4) way directional connections provide the desired distribution without ductwork when using gangable elbows or discharge registers.

GE GANGABLE ELBOWS — Each elbow covers 1/6 of the unit discharge opening and can be turned to direct the discharge air 45° in that direction. For 90° deflection of the discharge air, two (2) elbows may be joined together in series. Constructed of galvanized steel and painted. NOTE: Deflectors are available to increase discharge velocity.

DR DISCHARGE REGISTERS — Each 12" x 16" register covers 1/6 of the unit discharge and contain double deflection blades to direct the air where needed.

| Type | Static Pressure | Weight |
|------|-----------------|--------|
| DD | INCL. | 75# |
| Curb | N/A | 78# |
| MDD | .10 | 20# |
| ADP | .20 | 28# |
| GE | .10 | 1.25# |
| DR | .22 | 2.25# |

PHYSICAL DATA

total weight of 750 pounds

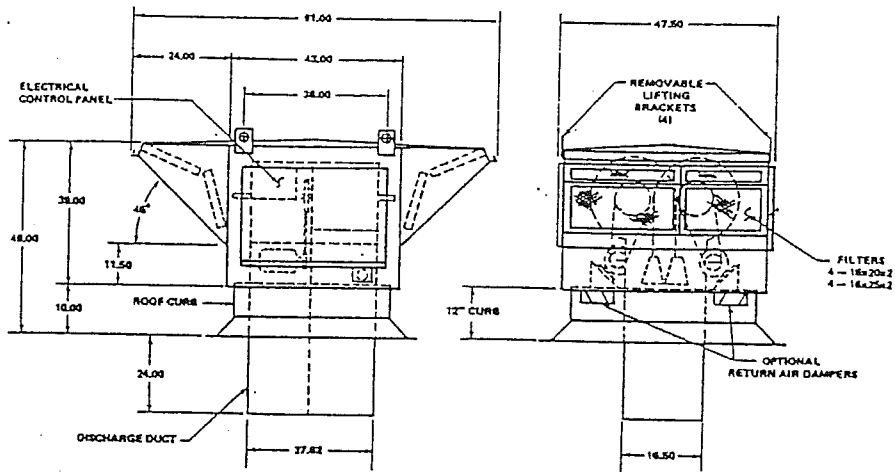

R215G

SPECIFICATIONS

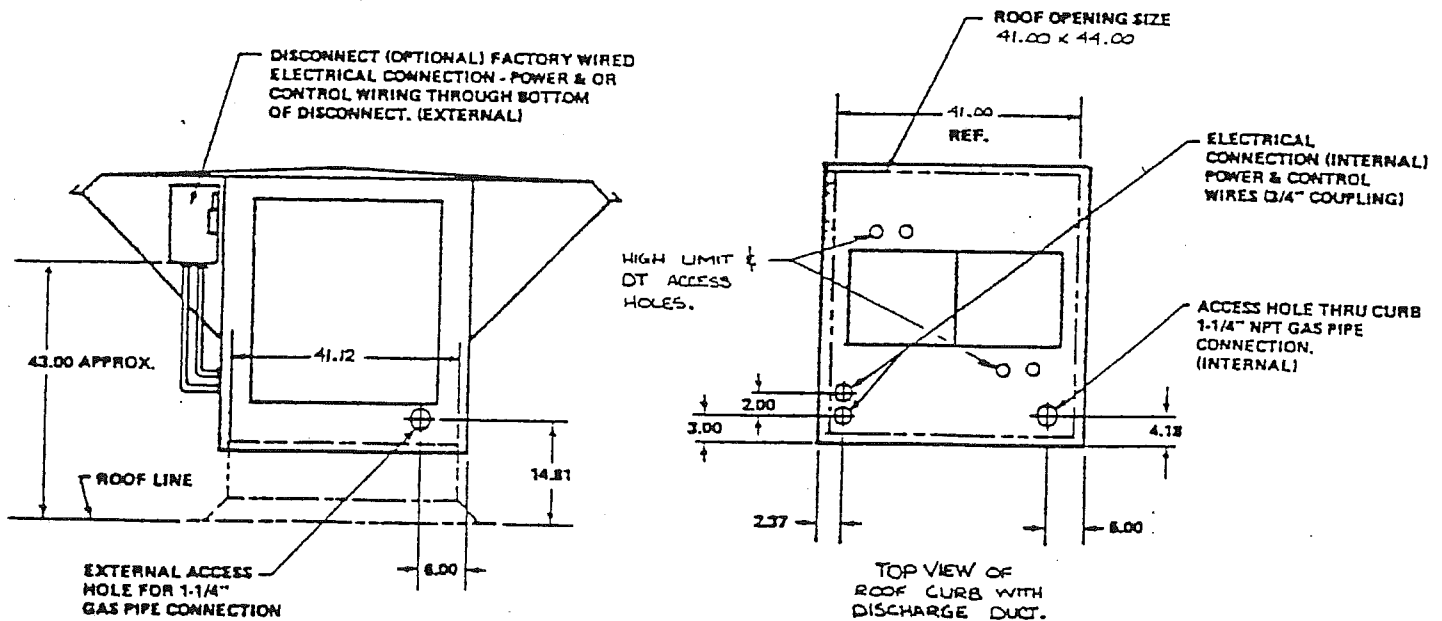

NOTE: Orientation of unit and curb should allow for servicing, unrestricted intake opening, and proper alignment with structural roof supports.

EQUIPMENT INSTALLATION DATA

I. INSTALL CURB

- a. Select location. Insure that roof penetration will clear roof trusses/supports.

-CAUTION-

Determine proper orientation of unit before proceeding. Keep in mind the need for unrestricted intake and discharge openings.

- b. Cut 44"x41" opening in roof.
- c. Position and secure curb. Flash and seal curb to prevent water leaks.

II. INSTALL DISCHARGE DUCT (DD)

- a. Slip duct into curb. Discharge duct base should sit squarely and seat properly on curb.
- b. Locate access holes for wiring, piping and note orientation of discharge duct.
- c. After duct is installed through roof, the accessory mounting flange on bottom sides of duct will have to be removed and turned so that discharge accessories can be accommodated.

III. INSTALL UNIT

- a. Rotate unit to match discharge duct access holes.

-CAUTION-

Check for proper alignment of piping and wiring connections.

- b. Secure unit to curb. Use holes provided.
- c. Remove lifting brackets from unit and reinstall.
- d. Run bulbs from high limit and discharge thermostat through access holes and mount to discharge duct (see next two pages for instructions).

DISCHARGE THERMOSTAT AND HIGH LIMIT MOUNTING

BULB SUPPORT - DUCT MOUNTING

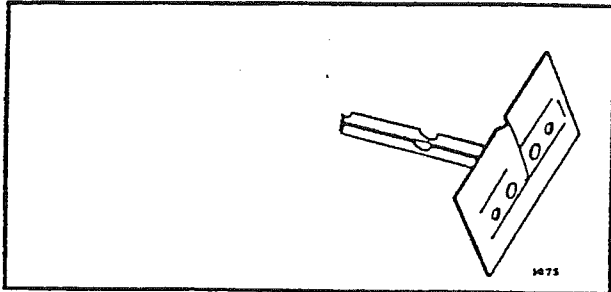

Fig. 1 Bulb Support

1. Run capillary & bulb of Discharge Thermostat and High Limit through access holes in discharge duct to location on side of duct (See Page for location).
2. Place capillary in bulb holder channel. Pinch top edges of holder together at each segment.

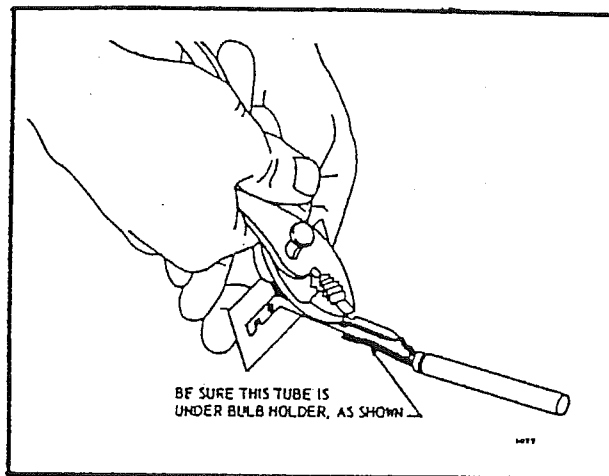
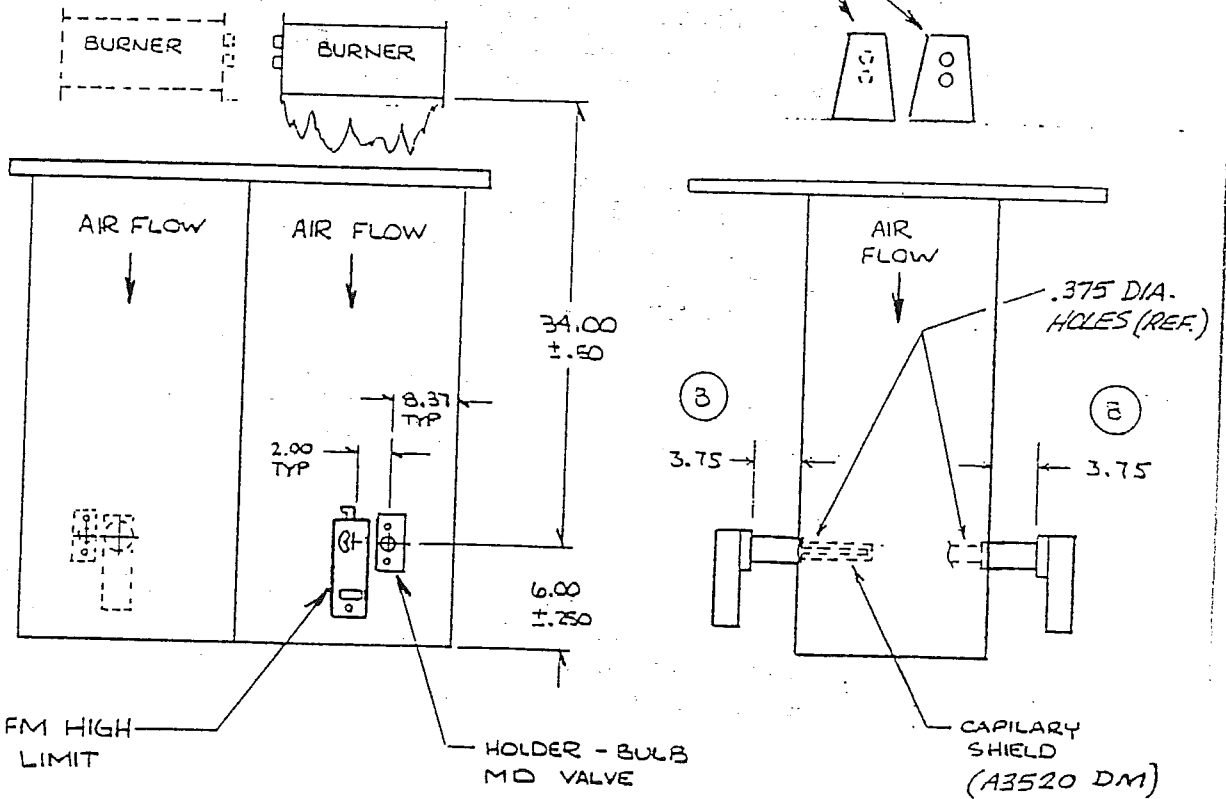
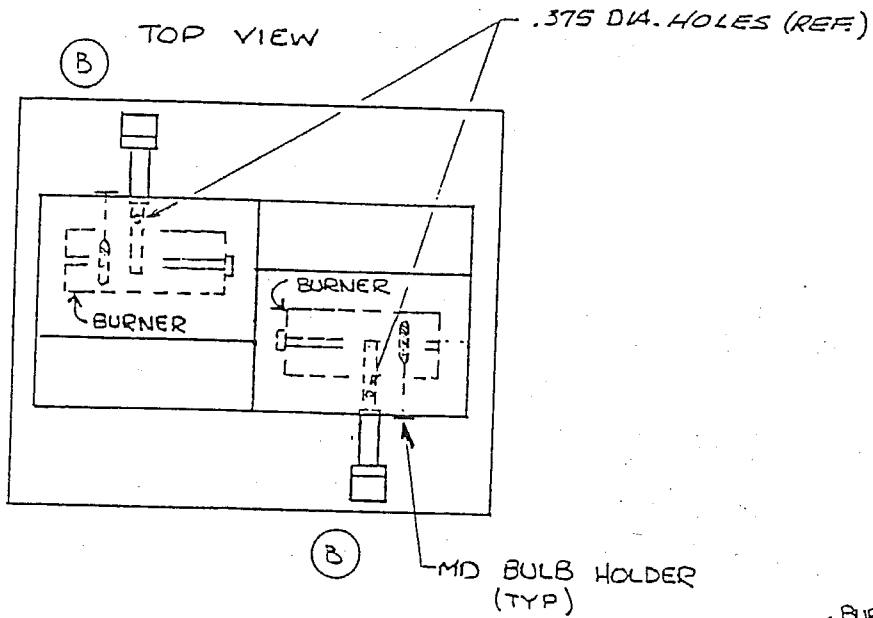

Fig. 2 Securing Cap in Bulb Holder

3. Insert bulb holder into discharge duct through factory holes.
4. Fasten bulb holder to duct wall with furnished screws.



This drawing is an instrument of service and is the sole property of Cambridge Engineering, Inc. It may not be copied, reproduced, or re-used on any other project without agreement in writing from this company.

FM HIGH LIMIT LOCATION
R215

| REVISION | No. | Date | No. | Date | No. | Date |
|----------|---------|------|-----|------|-----|------|
| A | 1-9-85 | | | | | |
| B | 2-27-85 | | | | | |

DWG. NO A3520 XY

by DAVE 2/5/82

CAMBRIDGE
ENGINEERING CORP

INSTRUCTIONS FOR FIELD INSTALLATION

OF

MOTORIZED DISCHARGE DAMPERS

- a. Mount MDD to discharge duct of unit with 1/4-20 bolts and lock washers. Louver linkage should be mounted down and away from unit.
- b. Mount ADP to the MDD.
- c. Install gangable elbows or discharge registers.
- d. Run conduit to unit J box from each DD motor and end switch.

SIDE 1 - Wire black lead of DD motor and red lead of DD motor end switch to 2 in unit J box. Wire white lead of DD motor to 3 in unit J box. Wire blue lead of DD motor end switch to 6 in unit J box.

SIDE 2 - Wire black lead of DD motor and red lead of DD motor end switch to 22 in unit J box. Wire white lead of DD motor to 23 in unit J box. Wire blue lead of DD motor end switch to 26 in unit J box. Cap yellow lead of DD motor end switch.

Discharge damper motor end switch must be adjusted per instructions on the following page.

-NOTE-

If MDD accessory was not part of original order, consult with Cambridge Systems Services department at (314) 532-2233 for additional instructions.

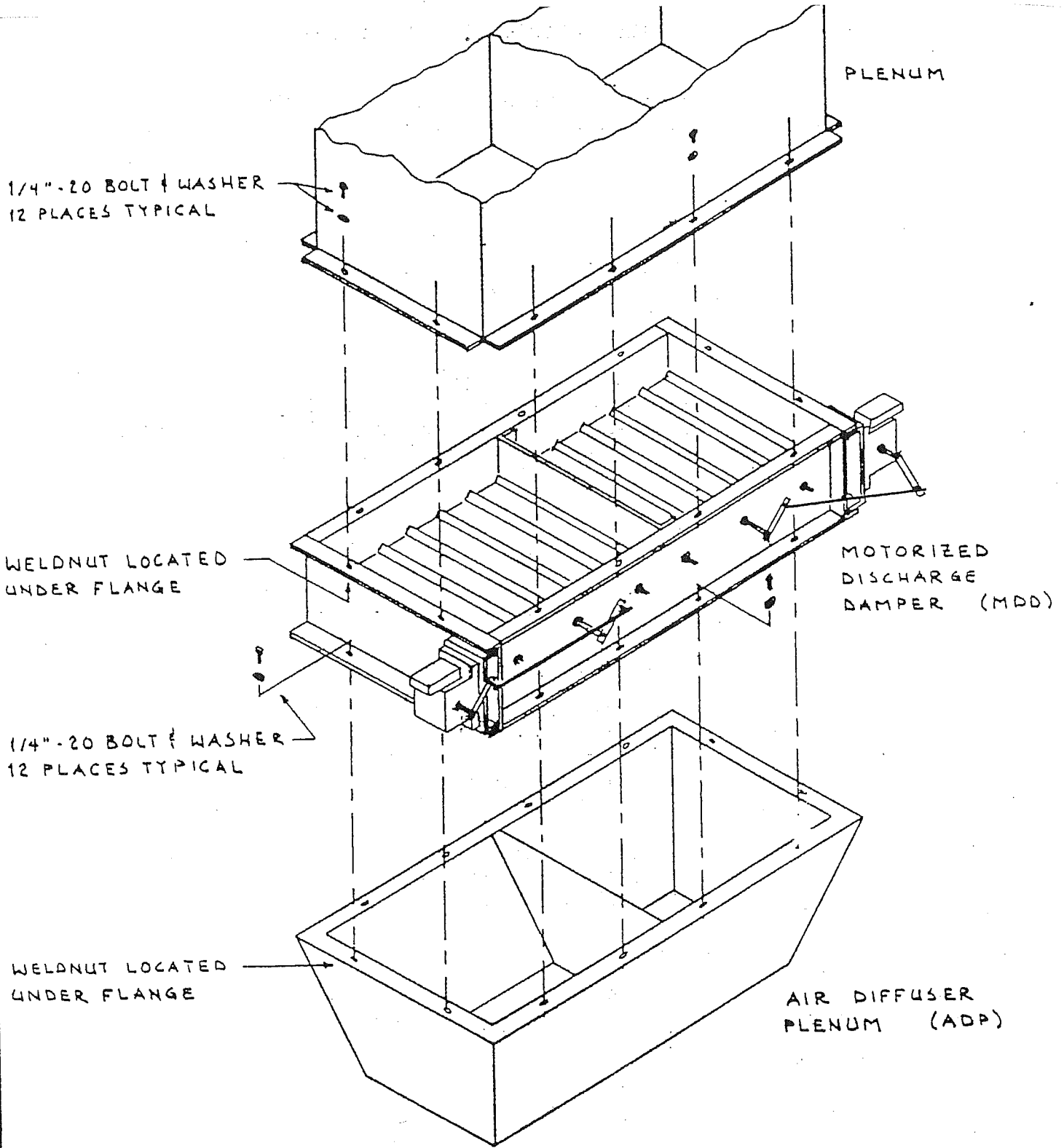

This drawing is an instrument of service and is the sole property of Cambridge Engineering, Inc. It may not be copied, reproduced, or re-used on any other project without agreement in writing from the company.

| REVISION | No. | Date | No. | Date | No. | Date |
|----------|-----|------|-----|------|-----|------|
| | | | | | | |
| | | | | | | |
| | | | | | | |

DWG. NO

by

CAMBRIDGE
ENGINEERING INC.

ELECTRICAL
INSTALLATION INSTRUCTIONS

Before attempting installation, review following instructions and wiring diagrams to make sure you have a thorough understanding of what is required.

-WARNING-

High voltage electrical input to this equipment is required. Extreme caution should be exercised.

-CAUTION-

This equipment must be electrically grounded in accordance with local codes or in accordance with National Electrical Code ANSI/NFPA No. 70-1984.

- a. Check nameplate on side of unit to determine electrical input requirements of equipment.
- b. Remove access panels on both sides of unit.
- c. Remove access covers of electrical control enclosures. Wiring diagram for this unit is located inside.
- d. Mount disconnect and connect primary wiring from unit per National Electrical Code.
- e. Mount Remote Control Station (RCS). This control should be located inside of building and convenient to operator without being susceptible to damage.
- f. Check type of control(s) provided.
- g. The following instruction is applicable to units having Operating Thermostat (OT-1), Space Thermostat (ST), 24 volt temperature controls, or night setback options.

Locate all thermostats out of the direct line of discharge air currents from unit and where they will maintain the desired comfort levels with maximum efficiency.

- h. Check type of control(s) provided.
- i. Wire Remote Control Station and other temperature control options per Cambridge wiring diagram and N.E.C.

-CAUTION-

Observe special notes and instructions on wiring diagrams.

- j. Run conduit and primary wiring to disconnect switch (per N.E.C.).

-WARNING-

Do not attempt to start unit at this time. Premature start-up can result in damage to equipment and components.

- k. Return wiring diagram to electrical control enclosure. Replace and fasten all access covers and panels.

GAS PIPING
INSTALLATION INSTRUCTIONS

-NOTE-

Refer to nameplate on side of unit to determine gas supply requirements.

-WARNING-

If supply pressure is in excess of 14" W.C., a separate positive shutoff high pressure regulator must be added upstream of the unit's individual shutoff valve. This regulator must be vented to outside of building with no reduction in size of the vent piping. Check with local utility or gas supplier for gas supply pressure.

HIGH PRESSURE REGULATOR SELECTOR CHART FOR CAMBRIDGE EQUIPMENT

| Gas Supply Pressure | 1/2 to 1# | 1.5 to 2# | 3 to 5# |
|------------------------------|---|---|---------------------------------------|
| Below 500,000 BTU/Hr. | HPR-1 1/2 Orifice Silver Spring | HPR-1 1/2 Orifice Silver Spring | HPR-1 1/2 Orifice Silver Spring |
| 500,000 to 650,000 BTU/Hr. | HPR-2 5/8x3/4 Orifice Silver Spring | HPR-1 1/2 Orifice Silver Spring | HPR-1 1/2 Orifice Silver Spring |
| 650,000 to 1,300,000 BTU/Hr. | HPR-3 7/8x1 Orifice Black Spring | HPR-2 5/8x3/4 Orifice Silver Spring | HPR-1 1/2 Orifice Silver Spring |

- a. Run piping to unit and secure per National Fuel Gas Code.

-NOTE-

A 1/8" N.P.T. plugged tapping accessible for manometer connection must be installed immediately upstream of the gas supply connection to the heater. An adequate drip leg must be installed as close to the inlet of the heater as practical. The piping must be properly sized for rated capacity, or in the absence of local codes with the National Fuel Gas Code; ANSI Z223.1-1984.

b. Check for leaks in supply piping system. Use soap solution.

-CAUTION-

If the test pressure is in excess of 1/2 PSIG (3.45 KPA), the heater and its manual shutoff valve must be disconnected from the gas supply system during pressure testing.

-CAUTION-

If the test pressure is less than or equal to 1/2 PSIG (3.45 KPA), the heater must be isolated from the gas supply piping by closing its manual shutoff valve during pressure testing.

-CAUTION-

Make sure all supply piping is free of foreign matter and purged.

-WARNING-

Do not attempt to start unit at this time. Premature start-up can result in damage to equipment and components.

CAMBRIDGE EQUIPMENT
START-UP WORK SHEET (SIDE 1)

JOB NAME _____ S.O.# _____
MODEL _____ SERIAL NO. _____
ELECT. SUPPLY VOLTAGE _____ GAS SUPPLY PRESSURE _____

BLOWER MOTOR

BLOWER MOTOR VOLTAGE _____ BLOWER MOTOR CURRENT _____ BLOWER RPM _____

MANIFOLD PRESSURE

SPECIFIED MANIFOLD PRESSURE (NAMEPLATE) _____
MANIFOLD STATIC PRESSURE (BLOWER ONLY) _____
ADJUSTED MANIFOLD PRESSURE _____

FLAME SIGNAL CHECK

MICRO-AMPS HIGH FIRE _____ MICRO-AMPS LOW FIRE _____

CONTROLLER SETTINGS

RECORD SETTING OF CONTROLS THAT ARE APPLICABLE TO THIS UNIT

MD _____ ST _____ DT _____
OT _____ DIFFERENTIAL _____ NSB _____

START UP PERFORMED BY _____

DATE _____

NOTE: This form is to be completed by person performing start-up and should remain as a permanent record with each individual unit. It will also be useful when communicating with factory and diagnosing problems.

START-UP WORK SHEET (SIDE 2)

JOB NAME _____ S.O.# _____

MODEL _____ SERIAL NO. _____

ELECT. SUPPLY VOLTAGE _____ GAS SUPPLY PRESSURE _____

BLOWER MOTOR

BLOWER MOTOR VOLTAGE _____ BLOWER MOTOR CURRENT _____ BLOWER RPM _____

MANIFOLD PRESSURE

SPECIFIED MANIFOLD PRESSURE (NAMEPLATE) _____

MANIFOLD STATIC PRESSURE (BLOWER ONLY) _____

ADJUSTED MANIFOLD PRESSURE _____

FLAME SIGNAL CHECK

MICRO-AMPS HIGH FIRE _____ MICRO-AMPS LOW FIRE _____

CONTROLLER SETTINGS

RECORD SETTING OF CONTROLS THAT ARE APPLICABLE TO THIS UNIT

MD _____ ST _____ DT _____

OT _____ DIFFERENTIAL _____ NSB _____

START UP PERFORMED BY _____

DATE _____

NOTE: This form is to be completed by person performing start-up and should remain as a permanent record with each individual unit. It will also be useful when communicating with factory and diagnosing problems.

START-UP PROCEDURE

-NOTE-

When performing start-up on R215 units, always begin with Side One of unit (J Box in lower left corner of service area).

-WARNING-

Read the following instructions carefully. Make sure you have a full understanding of start-up procedure. Any unauthorized modification to, or deviation from these instructions may void warranty.

STEP 1

INSTALLATION INSPECTION

- a. When installed, this heater must be electrically grounded in accordance with local codes or in the absence of local codes, with the National Electrical Code ANSI/NFPA No. 70-1984.
- b. Review wiring diagram (located in control panel of unit) and operating sequence. Review special controls and interlocks.
- c. With disconnect in "OFF" position, check for proper supply voltage and for adequate branch circuit protection in accordance with the National Electrical Code ANSI/NFPA No. 70-1984. (See nameplate for proper unit voltage.)

-WARNING-

Do not proceed with start-up unless supply voltage agrees with nameplate voltage. If supply voltage is not correct, check with your local agent or Cambride Engineering's Systems Services department to determine what changes are required to correct heater voltage.

- d. Turn off all gas using manual shutoff valves. A 1/8" N.P.T. tap accessible for manometer connection has been provided on the manual shutoff located immediately upstream of the gas supply connection to the heater. Verify that an adequate drip leg was installed as close to the inlet of the heater as practical. Check piping to insure that it has been properly sized for the required gas flow and that it conforms with local building codes or in the absence of local codes, with the National Fuel Gas Code ANSI Z223.1-1980.

-CAUTION-

Verify that all wiring and special controls are installed in accordance with manufacturer wiring diagrams and specifications.

- e. Check with local utility or gas supplier for gas supply pressure. If supply pressure is in excess of 14" W.C., a separate positive shutoff high pressure regulator is required upstream of the unit's individual shutoff valve. This regulator must be vented outside of the building with no reduction in the size of the vent piping. A bug vent must be installed at the line termination to prevent blockage of the line by insects.
- f. Check for leaks in supply piping system. Use soap solution.

-CAUTION-

If the test pressure is in excess of 14" W.C. (1/2 PSIG), the heater and its individual shutoff valve must be disconnected from the gas supply system.

-CAUTION-

If the test pressure is less than or equal to 14" W.C. (1/2 PSIG), the heater must be isolated from the gas supply piping by closing its individual shutoff valve during any pressure testing of the gas supply piping system.

- g. Reconnect piping to unit and open all manual shutoff valves.
- h. Refer to unit nameplate for motor horsepower rating and compare with nameplate on motors. Check belt tension and alignment. Verify that motor and fan pulley set screws are properly tightened.

-CAUTION-

Verify that all wiring and special controls are installed in accordance with manufacturer wiring diagrams and specifications.

STEP 2

BLOWER AND MOTOR ADJUSTMENTS

- a. Turn on disconnect switch.
- b. Burner switch is to remain in "OFF" position. Turn blower switch (at remote control station) for Side One to "LO" position. Blower should start (units with dampers will have slight delay before blower starts). Make sure damper is fully open. If not, refer to adjusting damper linkage and end switch section, Page 33. Check for proper fan rotation. This normally requires turning off blower and observing fan rotation as it slows down. If rotation is incorrect, turn disconnect switch "OFF" and reverse any two of the three motor leads on 3-phase motors. On single phase motors, follow reversing instructions on motor nameplate.
- c. Record blower RPM _____. Check and record motor voltage _____ and AMPS _____. Compare readings with those on nameplate. If voltage is correct and AMP readings are high, excessive blower RPM is indicated. Open motor pulley in 1/2 turn increments until AMP readings are equal to or less than shown on nameplate. Note: AMP readings on 3-phase should be the average of the three leads. RPM _____ AMPS _____. Check setting of overload relay to make sure it is properly adjusted. The reading on the dial adjusting screw should not exceed the FLA rating on motor nameplate.

STEP 3

ADJUSTING BURNER MANIFOLD PRESSURE

-NOTE-

Set all temperature controls to highest setting during start-up. Units having Entering Air Thermostat (EAT) option require moving wire from right terminal on the stat to left terminal. Units having Discharge Thermostat (DT) option require moving wire from "B" terminal to "R" terminal on stat.

- a. Turn off power to heater and "close" manual gas shutoff valve at manifold. Connect "U" tube manometer to 1/8" tap on manual shutoff valve at burner manifold. Turn on power and "open" manual gas shutoff valve to burner. Start the blower only and record a static pressure reading at the burner manifold. The burner static may be positive or negative. Record static reading _____. Now refer to nameplate on unit for specified manifold pressure. If a negative static reading was obtained, subtract that reading from the nameplate manifold pressure to obtain the correct "adjusted manifold pressure setting". If the burner static was positive, add this to nameplate manifold pressure to obtain the correct "adjusted manifold pressure setting". All readings and adjustments must be made with the unit running and the temperature control set on its highest setting. Adjustments during warm weather may require cycling of unit to keep burner at high fire. Turn on burner and adjust the regulator until actual manifold pressure agrees with the differential pressure obtained above.

-NOTE-

It may be necessary to temporarily jumper the airflow switch to permit the completion of the above step.

-NOTE-

If there is no flame and unit resets, wait one minute and depress reset button. Flame should appear. It may be necessary to repeat this procedure several times if gas piping was not purged. If unit fails after several tries, refer to troubleshooting section of manual.

FLAME SIGNAL CHECK

-WARNING-

Shut down entire system to prevent electrical shock.

- a. Remove wire from end of flamerod and connect "Positive" lead from microameter to end of flamerod. Connect other lead from meter to end of wire just removed.
- b. Start blower and burner. Turn MD valve to high fire setting and record meter reading _____. Reading on high fire should be greater than 7 microamps on the scale and should not fluctuate more than 5 microamps on scale. If fluctuations are greater than 5 microamps on scale, consult with factory.
- c. Turn MD valve to low fire setting (1) and record meter reading _____. Reading on low fire should be greater than 7 microamps on the scale and should not fluctuate more than 5 microamps on scale. If fluctuations are greater than 5 microamps on scale, consult with factory.

-NOTE-

Rapid cycling of the gas valve indicates fluctuating flame signal.

STEP 5

AIR FLOW SWITCH ADJUSTMENT

-NOTE-

Remove jumper if previously installed.

- a. With the burner operating, slowly adjust screw on airflow switch clockwise until burner goes out. Back the adjustment screw out quickly (counter-clockwise) until the burner lights. Note position of slot on screw and repeat several times to identify exact point of re-ignition. Back the adjustment screw out another 1/2 turn from the re-ignition point. This procedure will properly set the airflow safety switch.

STEP 6

BURNER IGNITION CHECK

- a. Adjust controllers from high to low fire setting and cycle several times at both conditions by turning burner on and off. Check for immediate ignition. This test should be tried with the unit hot and cold at both settings.

STEP 7

FLAME SAFEGUARD RELAY CHECK

- a. While burner is on, turn off gas at the burner manual shut-off valve. The Flame Safeguard Relay should trip within 4 seconds. Circuit breaker will then trip approximately 6 seconds later. Units with KVS option (local reset button) must be electrically cycled 4 or 5 times before circuit breaker will trip.

STEP 8

REMOVE TEST EQUIPMENT

- a. Turn electrical disconnect switch to "OFF" position and remove manometer, replace plug, disconnect microammeter and re-attach wire to flame rod. If unit has entering air thermostat or discharge thermostat, replace wires previously removed to original location.

STEP 9

RESTART UNIT

- a. Perform visual inspection of all wiring and gas valve plugs to be sure they have been properly replaced. Make sure all sensing bulbs (MD, etc.) are in their proper location. Turn electrical disconnect switch to "ON" position.

STEP 10

CHECK GAS TRAIN FOR LEAKS

- a. Operate unit at high fire. Check all pipe connections and plugs with liquid gas detector. Tighten joints as necessary.

STEP 11

CONTROLLER ADJUSTMENT

-NOTE-

A low temperature limit control should be installed in areas where freeze-up protection is needed in the event of burner shutdown. (See instructions on Page 27.)

-NOTE-

Before making any adjustments, read appropriate control instructions. (See Pages 24 thru 26.)

- a. Adjust temperature controller for desired heat level. MD setting should be placed on #6.

STEP 12

SECURE UNIT

- a. Place wiring diagram(s) inside control panel of unit and re-install control panel and unit access doors on this side.

STEP 13

PERFORM START-UP PROCEDURE ON SIDE 2

- a. Turn blower switch at RCS box to "high" position. Both blowers will operate. Repeat Steps 2 thru 13.

STEP 14

OPERATING CONTROLS CHECK

- a. Cycle unit several times at remote control station to insure proper operation. Set optional operating thermostat and controls to desired heat level.

REMOTE CONTROL STATION

I. SYSTEM SWITCH

- a. Manual Mode - Thermostat bypassed. "ON" and "OFF" manually controlled.
- b. Auto Mode - Thermostat will control "ON" and "OFF" cycles.

II. BLOWER SWITCH

- a. Low Position - Blower 1 energized.
- b. High Position - Blowers 1 and 2 energized.

III. HEATER SWITCH

- a. Low Position - Burner side 1 only.
- b. High Position - Burners 1 and 2.

MD CONTROL OPTION SUMMARY

General

This system utilizes a mechanical proportioning valve with a discharge-mounted bulb to maintain a constant discharge temperature. The bulb is located in the discharge airstream. The MD valve has an adjustment knob graduated from 1-9.

For Space Heating Application

The MD valve should be in #6 position. For space heating it is desirable to cycle the unit and this requires an optional Operating Thermostat. The "OT" (Operating Thermostat) must be connected across Terminals Z1 and Z2. (Terminals located in RCS.) The unit will now completely shut down when the space temperature satisfies the Operating Thermostat during the heating season.

For Constant Make-Up Air Application

The MD valve should be set to maintain a discharge temperature approximately 10°F warmer than the desired space temperature. For example -- in a building designed to have a space temperature of 65°F, the MD valve should be set to maintain about a 75°F discharge temperature (a setting of about #2 on the dial). An optional Entering Air Thermostat (EAT) should be installed to obtain maximum energy efficiency and prevent overheating during mild weather.

For Kitchen Ventilation Systems

The MD valve should be set to maintain a constant discharge temperature equal to the desired space temperature. For example -- for a kitchen designed to maintain 70°F, the MD valve should be positioned to maintain a discharge temperature of 70°F (a dial setting of #1).

EDS CONTROL OPTION SUMMARY

General

An EDS system consists of a Modulating Gas Valve (MV), a Discharge Thermostat (DT), and a Space Thermostat (ST). The discharge and space thermostats are connected in parallel. The discharge thermostat mounted in the unit will maintain a constant temperature until the space thermostat senses an uncomfortable condition. The space thermostat then overrides the discharge thermostat and raises the temperature to warm the conditioned area. When the desired temperature is reached, the discharge thermostat regains control. EDS controls will not cycle the unit "ON" and "OFF".

For Constant Make-Up Air Application

The discharge thermostat should be set at 10°F higher than the desired space temperature. The space thermostat should be set at the desired space temperature. An optional Entering Air Thermostat (EAT) should be installed to obtain maximum energy efficiency and prevent overheating during mild weather.

For Combination Make-Up Air and Space Heating Applications

The discharge thermostat should be set 10°F higher than the desired space temperature. Set the space thermostat at the desired space temperature. An exhaust fan interlock is necessary to satisfy makeup air requirements. To satisfy space heating when makeup air is not required, you must incorporate the use of an Operating Thermostat to cycle the unit "ON" and "OFF". The Operating Thermostat should be set 2°F to 5°F lower than the temperature setting of the space thermostat.

EDR CONTROL OPTION SUMMARY

General

This system consists of a Modulating Gas Valve (MV), a discharge thermostat and a remote manual controller (potentiometer). The Discharge Thermostat mounted in the unit will maintain a minimum discharge temperature. The remote manual controller (potentiometer) will allow the operator to raise the discharge temperature from the Remote Control Station. EDR controls will not cycle the unit "ON" and "OFF".

For Kitchen Ventilation System and Other Special Constant Make-Up Air Applications

Set the discharge thermostat at about 60°F. Do not set the discharge thermostat too high. The operator can increase or decrease the discharge temperature with the remote mounted potentiometer. An optional Entering Air Thermostat (EAT) should be installed to obtain maximum energy efficiency and to prevent overheating during mild weather.

LOW TEMPERATURE CUTOUT
FIELD INSTALLATION INSTRUCTIONS

Items Required:

- 1 - Time Delay Relay
 - a. 120 Volt coil
 - b. Adjustable from 3 - 300 seconds

- 1 - Thermostat
 - a. Line voltage
 - b. Open on rise
 - c. Range from 30° - 90°
 - d. Remote sensing bulb

Installation

- a. Install thermostat on side of discharge duct and mount remote sensing bulb in the discharge airstream. Connect thermostat to control panel using flexible conduit.
- b. Mount time delay relay in open space in bottom of control panel. Do not mount where it will hinder servicing of other components.
- c. Wire normally closed contact of time delay relay in series with existing motor starter coil. (See drawing below.)
- d. Wire thermostat and time delay relay coil in series with each other, and in parallel to the existing motor starter coil. (See drawing below.)
- e. Set thermostat for a minimum allowable discharge temperature (about 40° - 50°F).
- f. Adjust the time delay relay for approximately 120 seconds.
- g. Run unit through a cycle at normal discharge temperature, and then at an abnormally low discharge temperature to insure proper operation of all components.

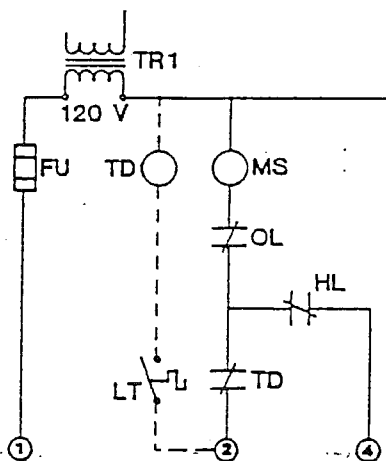

- TR 1 Control Transformer
- FU Fuse
- HL High Limit
- MS Motor Starter Coil
- OL Overload Heater Control
- TD Time Delay Relay
- Coil + Contact
- LT Low Limit Thermostat

Schematic - Low Temperature Cut-out Option

NIGHT SETBACK SYSTEM (INSTALLATION INSTRUCTIONS)

-WARNING-

DO NOT MOVE THE TIME POINTER. To set time, pull time dial outward and rotate in either direction until time pointer aligns with correct time of day.

-NOTE-

In the event of power failure, time dial will have to be reset with correct time of day.

INSTALLATION

NOTE:

- a. Connect terminals 1 + 3 to matching terminals in Cambridge unit, or to separate 120 volt power supply.
- b. This night setback control can handle up to three units. Unit #1 should be connected to terminals Z11 + Z12. Unit #2 should be connected to terminals Z21 + Z22. Unit #3 should be connected to terminals Z31 + Z32.

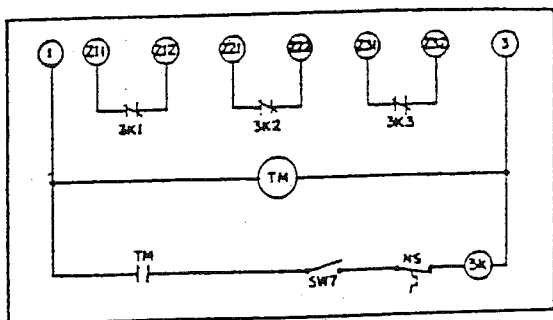

Circuit shown with manual lever in ON position

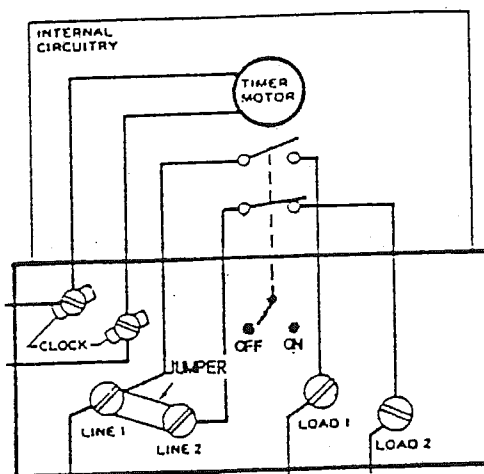

Manual lever in the OFF position.

TIME CLOCK FUNCTION

With the manual lever in the "ON" position, the timer contact for load 2 is open and the automatic heater control circuit functions normally through the operation of the Operating Thermostat (OT). (The 3K relay is not energized and therefore the normally closed 3K1, 2, and 3 contacts are closed.) When the "OFF" tripper passes by the manual level, it throws the lever to the "OFF" position which closes the timer contact for load 2. Provided the override switch (SW7) is closed, the 3K relay is energized and the normally closed 3K1, 2, and 3 contacts open. With the 3K1, 2, and 3 contacts open, the automatic heater control circuit cannot operate.

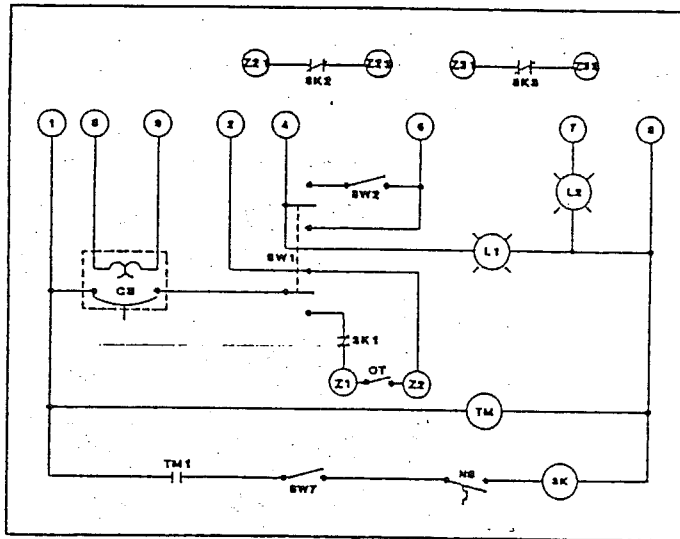

NSB THERMOSTAT FUNCTION

The night setback thermostat opens when the temperature drops below its setting which de-energizes the 3K relay and re-makes the normally closed 3K1, 2, and 3 contacts in the automatic heater control circuit. NOTE: The night setback thermostat is a refrigeration stat that makes on temperature rise and opens on temperature fall.

SETTING THE TRIPPERS

- a. Loosen the screw on the silver tripper labeled with "X".
- b. Move the "X" tripper around the edge of the time dial until it points to the time (AM or PM) you desire the manual lever to turn ON. (When the manual lever is turned ON, the timer contact for load 2 is open which permits normal operation of the heater in conjunction with the day stat.)
- c. Hold the tripper firmly against the edge of the dial and tighten the screw securely.
- d. Repeat Steps 1 through 3 for the OFF tripper (Black) setting the time you desire to switch the system OFF. (When the manual lever is turned OFF, the timer contact for load 2 is closed which permits the night thermostat to control the heater operation through the 3K relay.)

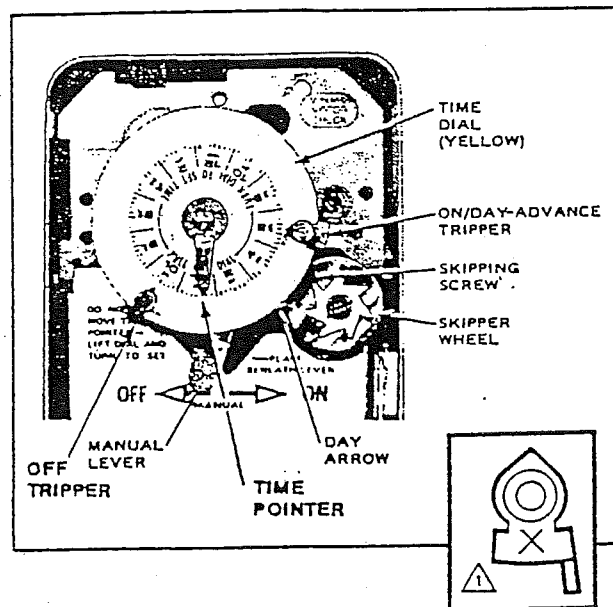

SETTING THE SKIP-A-DAY FEATURE

- a. Manual lever should be in the OFF position.
- b. Insert a skipping screw (or screws) in the skipper wheel for the day (or days) on which system is to remain off. Tighten the screw(s) firmly.
- c. Rotate the skipper wheel until the day arrow points to the correct day of week. (If the "X" tripper has not yet advanced the skipper wheel, the day arrow should point to the previous day.)

NIGHT SETBACK SYSTEM
(OPERATOR INSTRUCTIONS)

-WARNING-

DO NOT MOVE THE TIME POINTER. To set time, pull time dial outward and rotate in either direction until time pointer aligns with correct time of day.

-NOTE-

In the event of power failure, time dial will have to be reset with correct time of day.

AUTOMATIC OPERATION INSTRUCTIONS

- a. Place setback switch on front panel in "ON" position.
- b. Place blower switch in "AUTO" position.
- c. Place burner switch in "ON" position.

MANUAL OPERATION INSTRUCTIONS

Place lever on time clock to desired position. The manual lever can override the automatic operation of the time switch for the duration of one cycle only.

OPERATING SEQUENCE

POWER ON

- a. Control transformer energized.
- b. Operator must select manual (ON) or automatic (AUTO) mode.

SYSTEM SWITCH IN "MANUAL" MODE (OPERATOR CONTROLLED)

- a. Blower switch to "LO" position.
- b. Blower motor starts.
- c. Air flow switch closes.
- d. Heat switch to "LO" position.
- e. Gas valve opens.
- f. Ignition started.
- g. Burner lights.
- h. Ignition stopped.
- i. Unit continues to run until manually turned off.

-NOTE-

Placing blower and heater switches in "HI" position actuates both sides.

SYSTEM SWITCH IN "AUTO" MODE (THERMOSTAT CONTROLLED)

- a. Blower switch "HI" position; heater switch "HI" position.
- b. Power to operating stat or interlock (nothing occurs until this control calls for heat).
- c. Blower motor starts.
- d. Air flow switch closes.
- e. Gas valve opens.
- f. Ignition started.
- g. Burner lights.
- h. Ignition stopped.
- i. Unit runs until operating stat interlock opens (unit shuts off).
- j. Steps b. thru i. repeat themselves automatically as

INDIVIDUAL COMPONENT FUNCTIONS

DAMPER MOTOR WIRING

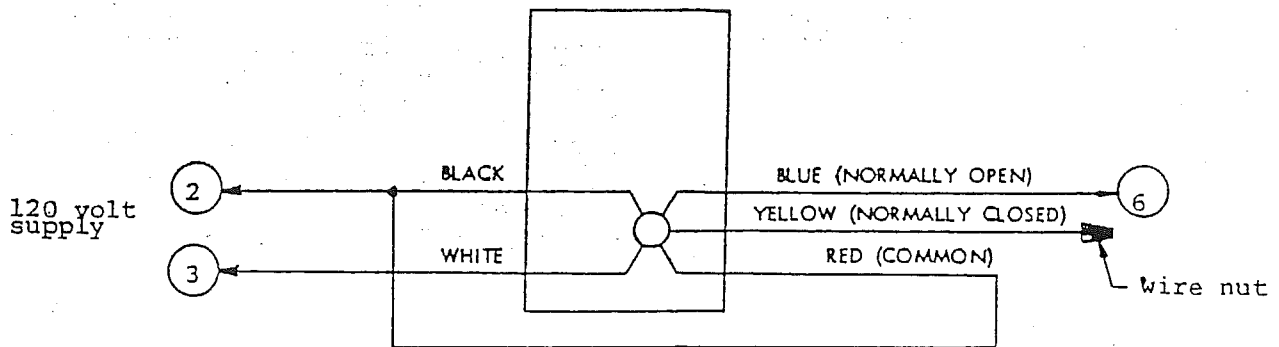

Terminals 2, 3 & 6 are located in control enclosure

AUXILIARY SWITCH ADJUSTMENT

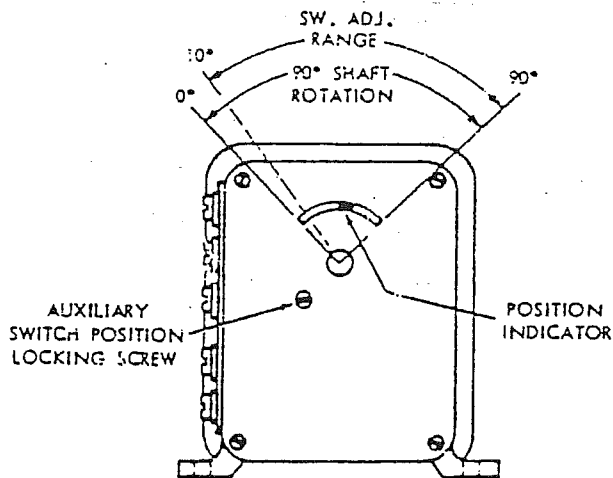

The internal SPDT auxiliary switch can be adjusted to operate between 10 and 90 degrees shaft rotation. The switch will close the R-B circuits (N.O. contacts) during the power stroke (shaft rotating counterclockwise, viewed from flange end).

To adjust switch proceed as follows:

- Loosen locking screw.
- Adjust position indicator to approximate midpoint of slot and tighten locking screw.
- Apply power to motor.
- Note system function when switch operates.
- If motor has not rotated far enough when switch operates, move indicator clockwise.
- If motor has rotated too far, move indicator counter-clockwise.
- Repeat power stroke and note system function.
- Re-adjust as necessary.
- Tighten locking screw.

HIGH TEMPERATURE LIMIT -

On FM and IRI units, this opens when discharge air temperature exceeds 150°F. Burner shuts off and may shut off blower. Manual reset is required. On non-FM and non-IRI, the high limit opens when discharge temperature exceeds 185°F and automatically resets when cooled.

AIR FLOW SWITCH -

Closes when blower forces air through pitot tube. Will not allow SOV to open unless airflow is detected.

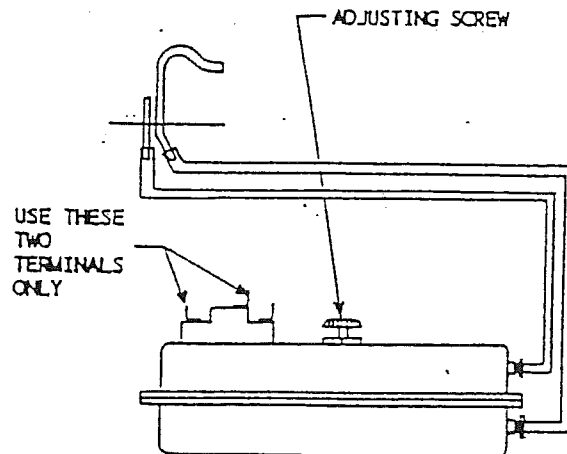

TRANSFORMER -

Supplies low voltage (120V) for control circuit.

FIRESTAT

- Safety device intended to shut down unit should air flow switch fail to shut off burner when blower stops. Manual reset required.

MD TEMPERATURE CONTROL VALVE

- Mechanical proportioning valve used to maintain constant discharge temperature. Sensing bulb is mounted in discharge airstream.

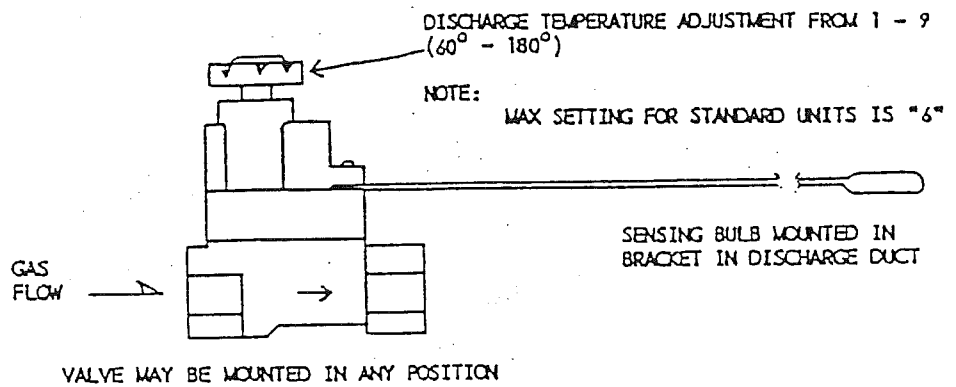

MV TEMPERATURE CONTROL VALVE

- An electronically controlled modulating gas valve. The electronic controls consist of a discharge thermostat that senses the discharge air temperature and a space thermostat that can override the discharge thermostat should ambient air temperature fall below desired space temperature set point.

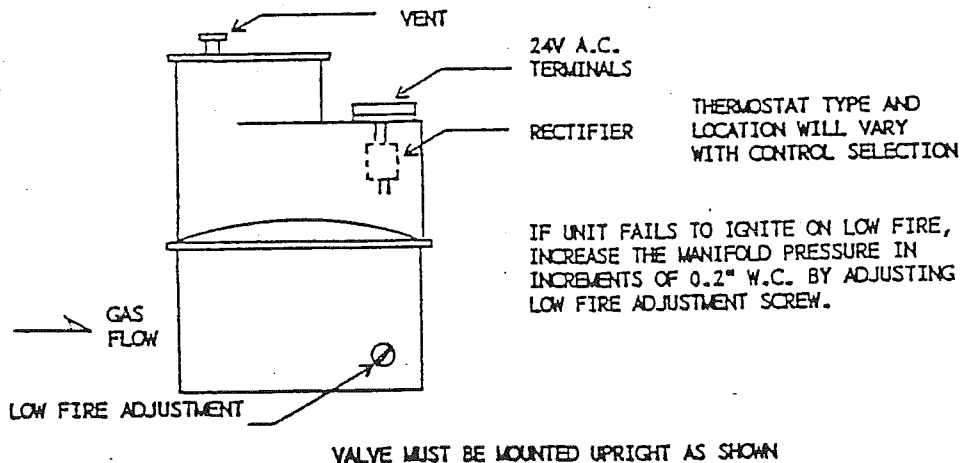

FLAME SAFEGUARD RELAY-

Applies control voltage to gas safety shutoff valve. Supplies ignition voltage to igniter. Senses absence/presence of flame through flame rod. Should loss of flame occur, FSR will attempt re-ignition. Circuit breaker will open if flame is not detected.

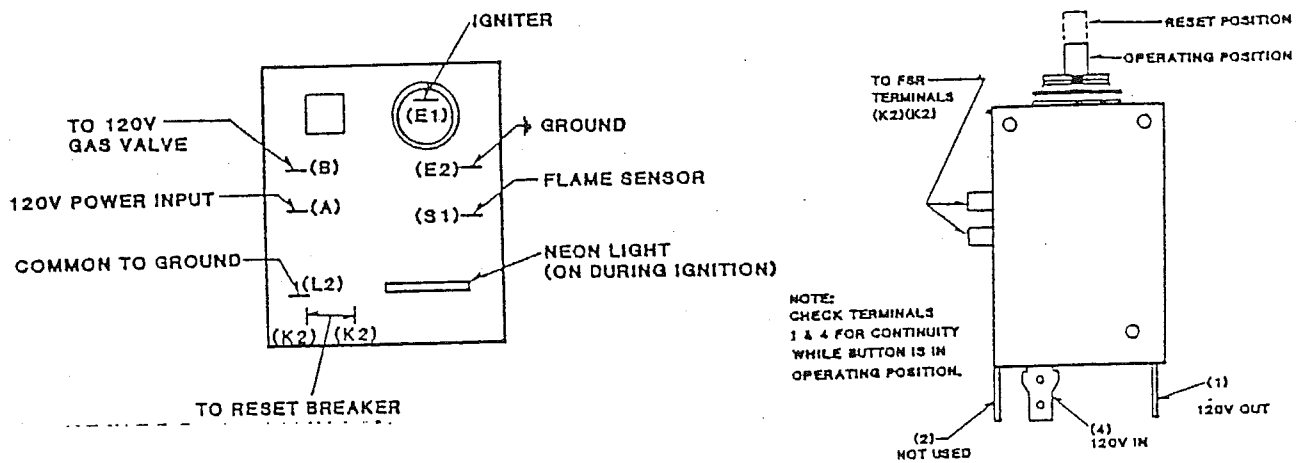

IGNITER

Provides spark to ignite gas in burner. (Plug is factory snipped.)

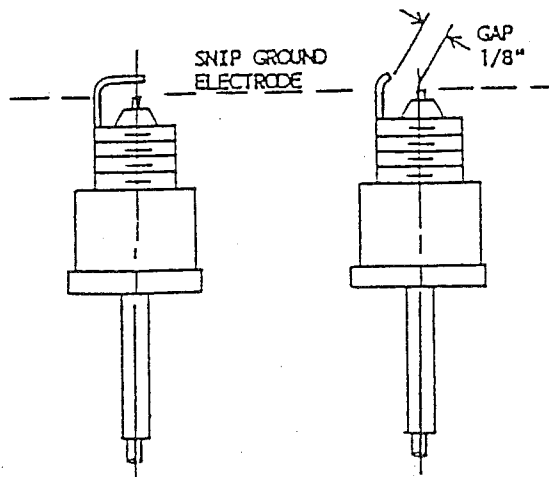

NOTE: GAP IGNITER AT 1/8" FOR FENVAL 05-14 SERIES IGNITION SYSTEMS

FLAME ROD

Senses flame and signals FSR to stop ignition. Also senses loss of flame.

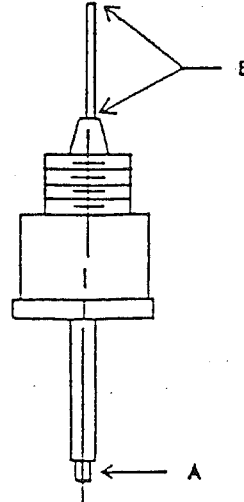

NOTES:

1. CHECK WIRE AT TERMINAL "A" FOR TIGHT CONNECTION.
2. CHECK FOR CONTINUITY FROM ALL OF PORTION B TO TERMINAL A. IF POOR OR NO READING, REPLACE FLAME ROD.

PRESSURE REGULATOR

Adjusted to hold constant and correct burner manifold pressure.

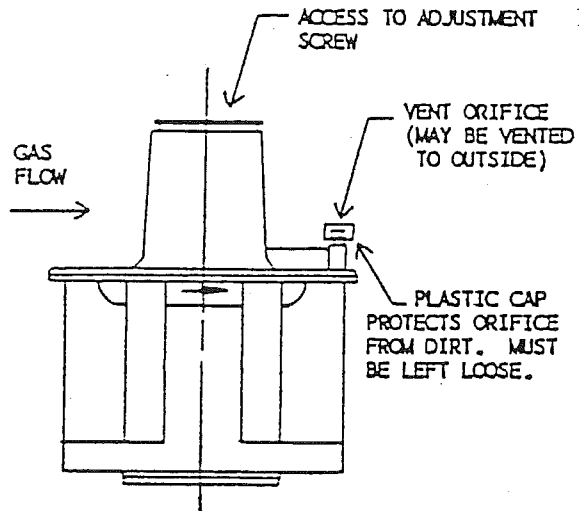

VALVE MUST BE MOUNTED UPRIGHT AS SHOWN.

HIGH LOW GAS
PRESSURE SWITCH -

A HLGP is installed on all IRI and FM gas trains of 400 MBH or greater. The HLGP is a safety to lock out the unit electrically should large gas pressure fluctuations occur. The high pressure switch should be set at 8" water column and the low pressure side should be set at 2" water column. Adjustment screws can be accessed by removing the two screws securing the top plate. The low pressure switch will have to be reset whenever gas is supplied to the unit gas train. Should gas be shut off downstream of the unit, the low pressure switch will have to be reset.

TROUBLESHOOTING GUIDE

| <u>PROBLEM</u> | <u>POSSIBLE CAUSE</u> | <u>CORRECTIVE ACTION</u> |
|------------------|---|---|
| <u>NO BLOWER</u> | 1. Flame Safeguard Relay Reset Breaker. A) Breaker in reset. B) Defective reset. | A) Depress reset button. B) Replace breaker. |
| | 2. Blower Switch. A) Switch in improper position. B) Defective switch. | A) Turn switch on. B) Replace switch. |
| | 3. Belts and Drives. A) Broken or loose belt. B) Broken or slipping pulley. | A) Replace or tighten belt. B) Tighten or replace pulley. |
| | 4. Control Transformer. A) No input voltage. B) Blown control fuse. C) Defective transformer. | A) Check disconnect and supply fusing. B) Replace control fuse. C) Replace transformer. |
| | 5. Motor Contactor. A) Defective contactor. B) No switching action. | A) Replace contactor. B) Replace or repair contactor. |
| | 6. Motor. A) Improper wiring. B) Defective motor. C) No input voltage. | A) Repair wiring. B) Replace motor. C) Check fusing. |
| | 7. Blower. A) Bad or locked bearings. B) Check for physical damage. | A) Replace bearings. B) Replace or repair blower. |
| | 8. Motor Protection. A) Overload relay tripped. B) Overload relay defective. C) Improper overload heater elements. | A) Check motor amps. B) Replace. C) Check heater selection with motor amps and volts. |

| <u>PROBLEM</u> | <u>POSSIBLE CAUSE</u> | <u>CORRECTIVE ACTION</u> |
|--|--|---|
| BLOWER RUNS; NO HEAT; DOESN'T RESET | 1. Hi-Temp Limit. A) May require manual reset. B) Open contacts in limit. | A) Push reset button. B) Repair or replace limit. |
| | 2. Flame Safeguard Relay. A) No input voltage. B) Faulty relay. | A) Check and repair wiring. B) Replace relay. |
| | 3. Reset Breaker. A) Faulty breaker. B) Missing breaker. | A) Replace breaker. B) Install breaker. |
| | 4. Burner Switch. A) Switch in wrong position. | A) Turn on switch. B) Replace switch. |
| BLOWER RUNS; NO HEAT; UNIT RESETS | 1. Igniter. A) Cracked porcelain. B) No spark. C) Bad lead. | A) Replace igniter. B) Check gap and burner compartment for good ground. C) Replace lead. |
| | 2. Gas Valve. A) No input voltage. B) Faulty solenoid. C) Locked up gas valve. | A) Check wiring and flame safeguard relay B) Replace solenoid coil C) Inlet pressure too high. May require high pressure regulator. |
| | 3. Regulator. A) Clogged vent orifice. B) No supply pressure. C) Defective regulator. D) Improper manifold pressure. | A) Clean or replace orifice. B) Check all gas cocks and piping. C) Replace regulator. D) Adjust regulator. |
| | 4. Air Flow Switch. A) Clogged pitot tube or tubing. B) No switching action. | A) Clean or replace tube and tubing. B) Adjust sensitivity of switch. |

PROBLEM

POSSIBLE CAUSE

CORRECTIVE ACTION

BLOWER RUNS;
NO HEAT;
UNIT RESETS
(CONT'D)

- 5. Low Air Flow.
 - A) Blocked intake or discharge.
 - B) Blower rotation.
- 6. Firestat.
 - A) Manual reset required.
 - B) Defective firestat.

- A) Find and remove blockage.
- B) Reverse motor direction.
- A) Determine reason for reset.
- B) Replace firestat.

BLOWER RUNS;
UNIT HEATS;
UNIT RESETS

- 1. Flame Rod.
 - A) Faulty flame rod or lead.
 - B) Flame rod not located in flame.
- 2. Flame Safeguard Relay.
 - A) Faulty relay.
 - B) Improper air flow across burner.
 - C) Defective burner.

- A) Replace flame rod or lead.
- B) Adjust burner flame to nameplate specification.
- A) Replace relay.
- B) Adjust air flow.
- C) Replace burner.

BLOWER RUNS;
UNIT HEATS;
SHORT CYCLE
WITHOUT RE-
SETTING

- 1. High Limit.
 - A) Defective limit.
- 2. Temperature Controller.
 - A) No modulation; discharge is too hot and unit is cycling on limit.
 - B) Faulty supply pressure.
- 3. Air Flow Switch.
 - A) Improper adjustment.
 - B) Defective switch.
 - C) Clogged or dirty pitot tube or tubing.
- 4. Faulty Safeguard Relay.
 - A) Faulty relay.

- A) Replace limit.
- A) Adjust or replace controller.
- B) Adjust regulator.
- A) Adjust switch.
- B) Replace switch.
- C) Clean or replace pitot tube or tubing.
- A) Replace relay.

PROBLEM

POSSIBLE CAUSE

CORRECTIVE ACTION

BLOWER RUNS;
UNIT HEATS;
INADEQUATE
HEAT OUTPUT

1. Regulator Adjustment.
 - A) Wrong size spring.
 - B) Regulator not properly adjusted.
 - C) Clogged vent orifice.
 2. Temperature Controller Adjustment.
 - A) Control bulb in wrong location.
 - B) Controller setting is too low.
 - C) Defective controller.
 3. Inadequate Gas Supply.
 - A) Regulator adjustment.
 - B) Improper regulator.
 - C) Pipe too small.
 - D) Supply pressure too low.
- A) Replace spring.
B) Adjust regulator.
C) Clean or replace vent on regulator.
A) Mount bulb in bracket provided.
B) Adjust temperature controller.
C) Replace controller.
A) Adjust regulator.
B) Check flow capacity on regulator; replace as needed.
C) Check flow capacity of pipe; replace as needed.
D) Call utility company.

MAINTENANCE INSTRUCTIONS

-WARNING-

Place electrical disconnect switch in "OFF" position when performing the following.

1. Motor bearings should be lubricated at one year intervals. Use Shell Dolium R, medium consistency, Polyurea lubricant. Blower bearings are permanently lubricated.
2. Drive belts should be checked for proper adjustment after each season's use. Check for a belt deflection of $3/8$ to $1/2$ " with a 6 to 7 lb. force applied inwardly at the center of the belt span.
3. Blower wheel should be examined periodically for accumulation of dust on the concave side of the blades. These surfaces must be kept clean as any dirt loading will result in greatly reduced air flows.
4. Annual check should be made of burner and components. Check burner plates for carbon buildup and clean if necessary. Clean igniter and flame rod and examine porcelain for cracks. Refer to burner cleaning procedures on next page.
5. Periodically check gas control assembly, internal and external piping for leaks. Relief vents on gas controls should be checked for clogging.
6. An annual check of the pitot tube for the air flow switch should be made to insure against stoppage.

BURNER CLEANING PROCEDURE

The Cambridge Engineering burner is for the most part self-cleaning; however, if the application is extremely dirty or dusty, it may become necessary to periodically clean the burner. Remove and clean the burner in accordance with the following recommended procedures:

- 1) Shut off electrical disconnect to unit. Shut off the gas cock that supplies gas to the unit.
- 2) Loosen unions in the gas train and relocate gas train assembly out of way for burner removal.
- 3) Disconnect ignition cable and flame sensor lead from burner and then remove flame rod and ignition plug.
- 4) Remove fasteners that secure burner to housing. Burner will be free to lift out with removal of the last fastener.
- 5) Clean burner by back-flushing the burner using high pressure air (40-80#). Be sure to take necessary safety precautions such as wearing eye protection, etc., before attempting this step. Continue back-flushing until dust particles are completely expelled from burner.
- 6) Reassemble burner, using above steps in reverse order.

LIMITED WARRANTY

THE COMPANY WARRANTS ITS MANUFACTURED PRODUCTS TO BE FREE FROM DEFECTS IN MATERIAL AND WORKMANSHIP FOR A PERIOD OF TWELVE (12) MONTHS FROM DATE OF FIRST INSTALLATION, OR FIFTEEN (15) MONTHS FROM DATE OF SHIPMENT, WHICHEVER OCCURS FIRST, PROVIDED THE PRODUCT IS PROPERLY INSTALLED AND OPERATED UNDER NORMAL CONDITIONS IN ACCORDANCE WITH COMPANY'S OPERATION AND INSTALLATION INSTRUCTIONS AND LOCAL CODES.

MISUSE OR MISAPPLICATION OF THE PRODUCT FROM ITS ORIGINAL DESIGN OR SPECIFICATIONS, OR CHANGES IN ORIGINAL SPECIFICATIONS OR OPERATING CONDITIONS, WITHOUT WRITTEN PERMISSION FROM THE COMPANY SHALL VOID THIS SUMMARY.

THE COMPANY'S OBLIGATION HEREUNDER SHALL BE LIMITED TO THE REPAIR, OR AT ITS OPTION, REPLACEMENT OF DEFECTIVE PARTS RETURNED TO THE COMPANY'S FACTORY, TOGETHER WITH ORIGINAL SHOP ORDER REFERENCE AND SERIAL NUMBER OF HEATER. SHIPPING CHARGES SHOULD BE PREPAID. REPLACEMENT PARTS PROVIDED SHALL NOT EXTEND THIS WARRANTY FOR THE PART(S) OR PRODUCT(S). THE COMPANY SHALL HAVE NO RESPONSIBILITY UNDER THIS WARRANTY UNLESS AND UNTIL THE PRODUCT HAS BEEN PAID FOR IN FULL, ACCORDING TO TERMS OF SALES CONTRACT, AND THEN THE COMPANY'S LIABILITY SHALL BE LIMITED TO THE COST OF REPAIR, BUT IN NO CASE IN EXCESS OF THE ORIGINAL PURCHASE PRICE OF THE DEFECTIVE PRODUCT.

THE WARRANTY DOES NOT APPLY TO FIELD LABOR CHARGES OR TO PRODUCTS WHICH HAVE BEEN ABUSED, IMPROPERLY OPERATED, SUBJECTED TO ABNORMAL WEAR AND TEAR, DAMAGED AS A RESULT OF IMPROPER GAS OR ELECTRIC SERVICE, OR DAMAGED IN TRANSIT, OR BY MISUSE, NEGLIGENCE OR ACCIDENT, OR TO PRODUCTS WHICH HAVE BEEN REPAIRED OR MODIFIED WITHOUT AUTHORIZATION FROM THE COMPANY. THE COMPANY DOES NOT WARRANT PRODUCTS MANUFACTURED BY OTHERS. ANY CLAIMS WITH REGARD TO SUCH PRODUCTS MUST BE DIRECTED TO THE ORIGINAL MANUFACTURER.

THE COMPANY MAKES NO WARRANTY OTHER THAN STATED ABOVE. ALL OTHER WARRANTIES EXPRESS OR IMPLIED, INCLUDING ANY IMPLIED WARRANTIES REGARDING PERFORMANCE, APPLICATION OR FITNESS FOR A PARTICULAR PURPOSE, ARE HEREBY EXCLUDED AND DISCLAIMED. THE COMPANY ASSUMES NO LIABILITY FOR ANY INCIDENTAL, CONSEQUENTIAL, SPECIAL OR ECONOMIC DAMAGES UNDER ANY WARRANTY, EXPRESS OR IMPLIED OR OTHERWISE, AND ALL SUCH LIABILITY IS HEREBY EXPRESSLY EXCLUDED AND DISCLAIMED.